

BESSER

HARMONIC DEPALLETER

MODEL DP-12 • SIX AT A TIME

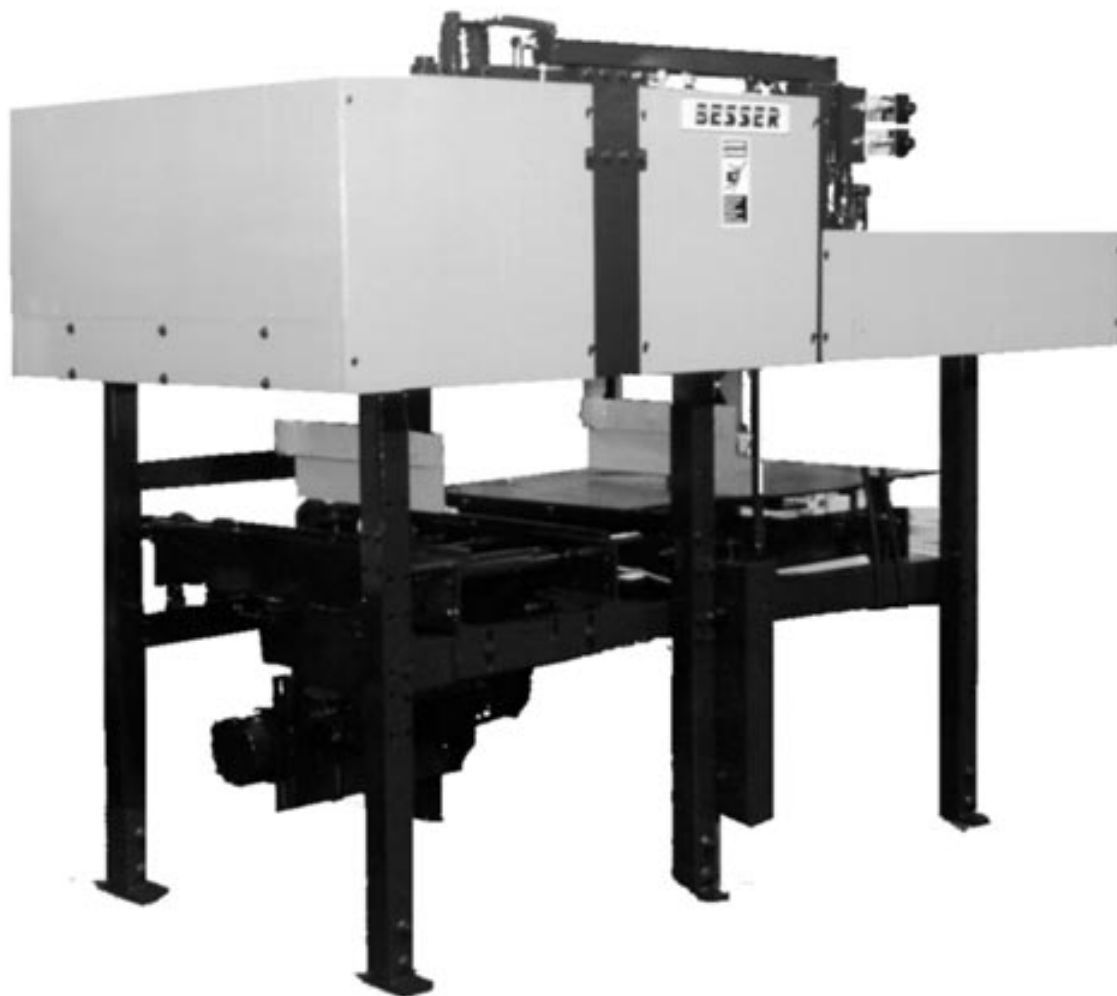

INSTALLATION MANUAL

466360F9901US

JUNE 1999 • US\$250

BESSER World Headquarters

801 Johnson St. • Alpena, Michigan, 49707 • U.S.A.
Phone (517) 354-4111

BESSER

COMPANY NAME:

SERIAL NUMBER:

ASSEMBLY NUMBER:

WIRING DIAGRAM NUMBER:

INSTALLATION DRAWING NUMBER:

6-AT-A-TIME DEPALLETER

TABLE OF CONTENTS

LIST OF FIGURESii
SPECIFICATIONSiii
SAFETY BULLETINiv
SAFETY SIGNSv
DECALSix
SECTION 1 INTRODUCTION	
1.1 General1-1
1.2 Depalleter Installation1-1
1.3 Hydraulic Connections1-3
1.4 Electrical Connections1-3

6-AT-A-TIME DEPALLETER

LIST OF FIGURES

1.1	Installation	1-1
1.2	Leg Extension Adjustment	1-2

6-AT-A-TIME DEPALLETER SPECIFICATIONS

















TOTAL WEIGHT:	2,000 pounds [907.2 Kg]
MINIMUM HYDRAULIC PRESSURE:	850 psi [58 bar]
MACHINE SPEED:	
RECOMMENDED:	10 cycles per minute
MAXIMUM:	12 cycles per minute
PRODUCTION CAPACITY:	Strips any concrete product up to 12 inches [305 mm] high from pallet
OIL REQUIREMENTS:	12 gpm total [56.7 lpm], 6 gpm crank motor [22.7 lpm], 12 gpm pusher cylinder [45.4 lpm]
	Note: The above gpm recommendations are for use with a block machine cycle rate of 10 or less. For a faster cycle rate, more capacity (gpm) are required. Use Shell Tellus 46 oil (or equivalent).
OPERATING CONDITIONS:	Besser machinery and equipment is designed to comply with the essential health and safety regulations (EHSR) that apply to directives which are applicable to an industrial environment. Buyer shall utilize this equipment in a manner consistent with its design and only in an industrial environment.
OPERATING RANGES:	Here are the normal operating ranges for machine sensors (limit, proximity) and control devices contained within the control panels.
Ambient operating temperature range:	32° to 131°F [0° to 55°C]
Humidity range:	5 to 95% (non-condensing)
Line voltage:	85 to 132 volts – AC 50/60 Hz

SAFETY BULLETIN

This notice is issued to advise you that some previously accepted shop practices may not be keeping up with changing Federal and State Safety and Health Standards. Your current shop practices may not emphasize the need for proper precautions to insure safe operation and use of machines, tools, automatic loaders and allied equipment and/or warn against the use of certain solvents or other cleaning substances that are now considered unsafe or prohibited by law. Since many of your shop practices may not reflect current safety practices and procedures, particularly with regard to the safe operation of equipment, it is important that you review your practices to ensure compliance with Federal and State Safety and Health Standards.

IMPORTANT

The operation of any machine or power-operated device can be extremely hazardous unless proper safety precautions are strictly observed. Observe the following safety precautions:

-  Always be sure proper guarding is in place for all pinch, catch, shear, crush and nip points.
-  Always make sure that all personnel are clear of the equipment before starting it.
-  Always be sure the equipment is properly grounded.
-  Always turn the main electrical panel off and lock it out in accordance with published lockout/tag-out procedures prior to making adjustments, repairs, and maintenance.
-  Always wear appropriate protective equipment like safety glasses, safety shoes, hearing protection and hard hats.
-  Always keep chemical and flammable material away from electrical or operating equipment.
-  Always maintain a safe work area that is free from slipping and tripping hazards.
-  Always be sure appropriate safety devices are used when providing maintenance and repairs to all equipment.
-  Never exceed the rated capacity of a machine or tool.
-  Never modify machinery in any way without prior written approval of the Besser Engineering Department.
-  Never operate equipment unless proper maintenance has been regularly performed.
-  Never operate any equipment if unusual or excessive noise or vibration occurs.
-  Never operate any equipment while any part of the body is in the proximity of potentially hazardous areas.
-  Never use any toxic flammable substance as a solvent cleaner.
-  Never allow the operation or repair of equipment by untrained personnel.
-  Never climb or stand on equipment when it is operational.

It is important that you review Federal and State Safety and Health Standards on a continual basis. All shop supervisors, maintenance personnel, machine operators, tool operators, and any other person involved in the setup, operation, maintenance, repair or adjustment of Besser-built equipment should read and understand this bulletin and Federal and State Safety and Health Standards on which this bulletin is based.

SAFETY SIGNS

Sign	Description	Required
1	All Panels	1
2	Mixer	4
3	Concrete Products Machine.....	1
	Depalleter	2
4	Mixer	2
5	Skiploader	4
6	Skiploader/Mixer Platforms	8
7	Skiploader/Mixer Platforms	8
8	Vertical: Pallet Transport System	2
	Horizontal: LSC-40A/LSC-100	6
	Pallet Transport System	4
9	Besser-Matic	4
10	Besser-Matic	4
11	Skiploader	4
12	All Panels	1
13	Overhead Block Transfer	4
14	Concrete Products Machine.....	1
15	Concrete Products Machine.....	2
16	Conveyors	12
17	Cuber	8
18	Cuber	3
	Block Turnovers.....	2
	Slat Conveyors.....	2

**To order safety decals, contact your local Besser representative
or the Besser Central Order Department.**

Thank you!



1
Large 113236F0409
High Voltage
Width 4 1/2 inch
Height 9 5/8 inch
Small 113236F0204
High Voltage
Width 2 inch
Height 4 1/8 inch



2
113237F0410
Mixer Blade Hazard
Width 4 1/2 inch
Height 10 1/4 inch



3
113240F0307
Crush Hazard
Width 3 1/2 inch
Height 7 1/2 inch



4
114692F1006
Nip Points
Width 5 3/4 inch
Height 9 1/2 inch



5
114688F0906
Crush Hazard
Width 6 1/4 inch
Height 9 1/2 inch



6
114689F0804
Fall Hazard
Width 4 1/2 inch
Height 7 3/4 inch



7

114690F0805
Falling Objects
Width 4 3/4 inch
Height 8 inch



8

Vertical: 113245F0704
Crush Hazard
Width 4 1/8 inch
Height 7 inch
Horizontal: 113245F1005
Crush Hazard
Width 10 inch
Height 5 3/4 inch



9

113242F0409
Crush Hazard
Width 4 1/2 inch
Height 9 5/8 inch



10

113243F0410
Falling Objects
Width 4 1/2 inch
Height 10 inch



11

114691F1006
Shear and Fall Hazards
Width 5 3/4 inch
Height 9 3/4 inch

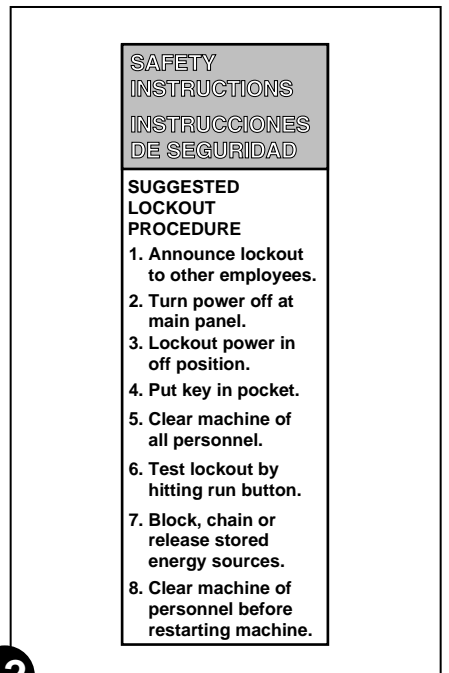

12

113249F0410
Safety Instructions Decal –
Suggested Lock-out Procedure
Width 4 inch
Height 10 inch

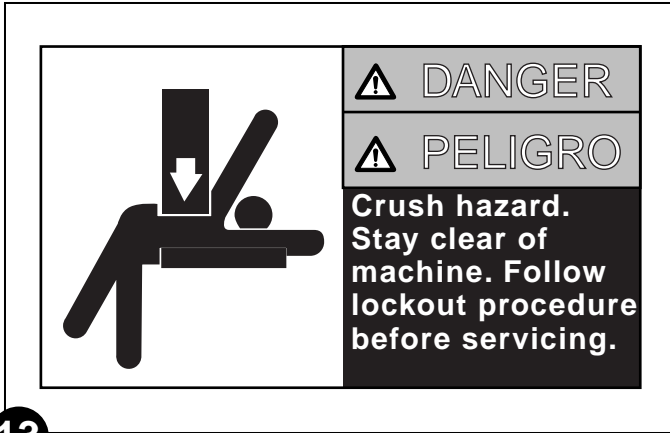

13

113238F1005
Crush Hazard
Width 10 inch
Height 5 3/4 inch

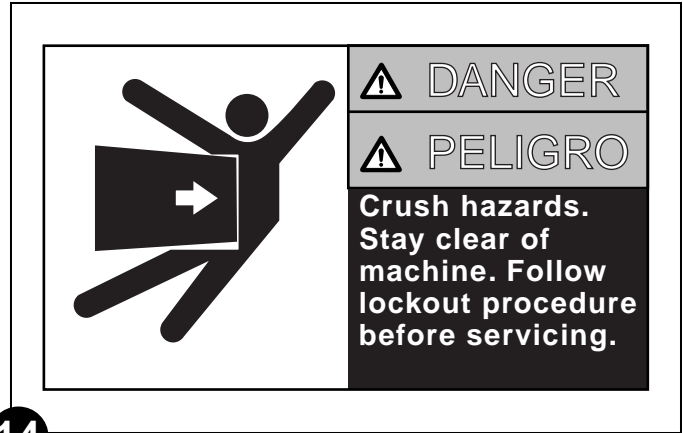

14

113239F0604
Crush Hazard
Width 6 5/8 inch
Height 4 inch

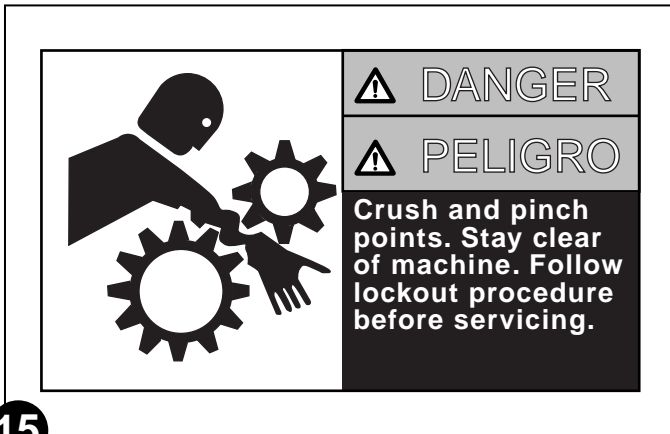

15

113241F0605
Crush and Pinch Points
Width 6 5/8 inch
Height 4 inch

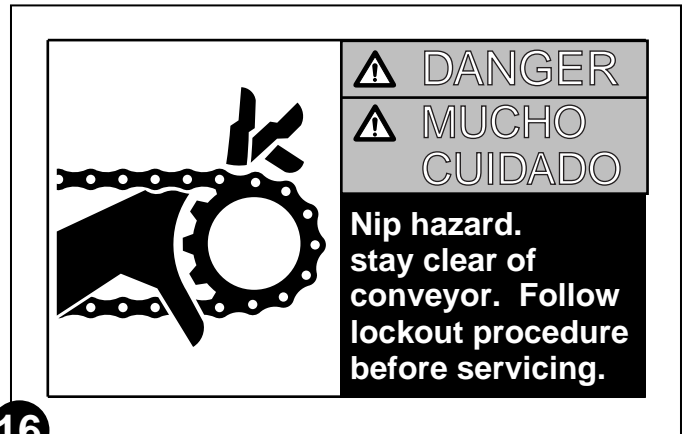

16

113246F0704
Nip Hazard
Width 7 inch
Height 4 1/2 inch



17

113427F1006
Crush Hazard
Width 10 inch
Height 6 inch



18

113250F1006
Crush and Pinch Hazard
Width 10 inch
Height 6 inch

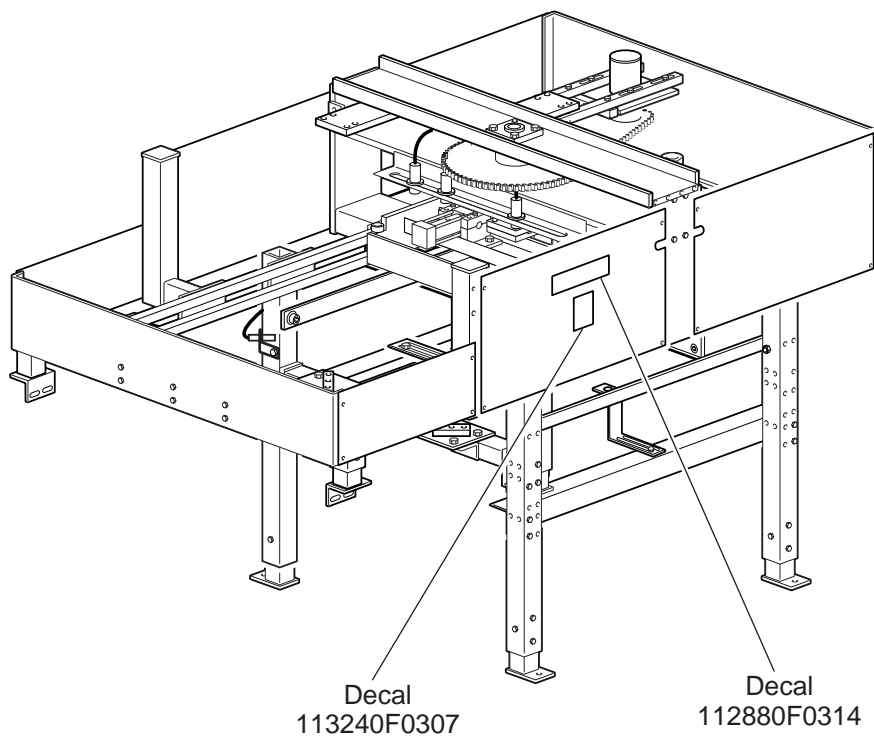

Figure A Decals

SECTION 1

INSTALLATION

1.1 GENERAL

The depalleter is assembled, tested, and adjusted at the factory. This reduces the installation procedures to those listed below:

- 1.2 Depalleter Installation
- 1.3 Pallet Support Adjustment
- 1.4 Hydraulic Connections
- 1.5 Electrical Connections

1.2 DEPALLETER INSTALLATION

**WARNING:**

Use of a non-professional rigging crew may result in personal injury and/or property damage.

2. Move the depalleter to the desired position. Verify that the first depalleter is in the proper orientation to the conveyor.
3. Place an empty pallet on the conveyor. Adjust the depalleter up or down until the pallet is approximately 1/16 inch [1.6 mm] higher than the wear plate (Figure 1.1, ref. A).

NOTE:

If necessary, install shims beneath the extension plates to obtain the 1/16 inch [1.6 mm] height difference. Save any remaining shims for future use to adjust for plate wear.

Follow this procedure to properly install each of the depalleters in relation to your conveyor configuration.

1. Secure the depalleter to a forklift or other lifting device.

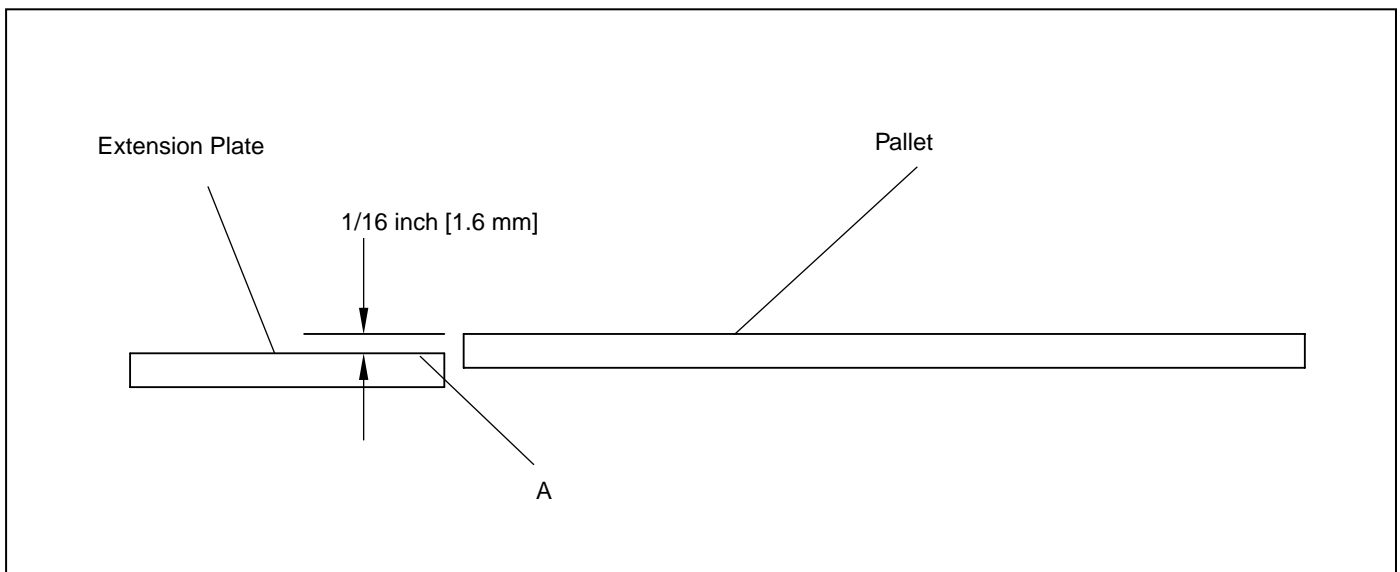

Figure 1.1 Installation

4. When the depalleter is in the proper orientation and at the proper height, loosen the three capscrews on each of the six legs to allow the extensions to slide down to the floor. Tighten all bolts on the legs to lock the extensions in place. For additional security, perform either of the following (see Figure 1.2):
 - Tack weld the leg extensions to the leg.
 - Position key stock so that it rests against the bottom of the leg and the side of the leg extension. Weld the key stock in place.
5. At all six legs, mark the floor at the hole in the base of the leg extension.

NOTE:

If necessary, move the depalleter out of the way to perform Step 6. Return it to perform Step 7.

6. Install the desired attaching hardware, using the floor marks (Step 5) as a guide.
7. Secure and level the depalleter.
8. After the first depalleter has been properly leveled and secured, carefully remove it from the forklift or lifting device.
9. To install the second depalleter, repeat steps 1 through 8. The actual floor placement of the second depalleter will vary according to conveyor configuration. Refer to the Installation Drawings for specific placement.

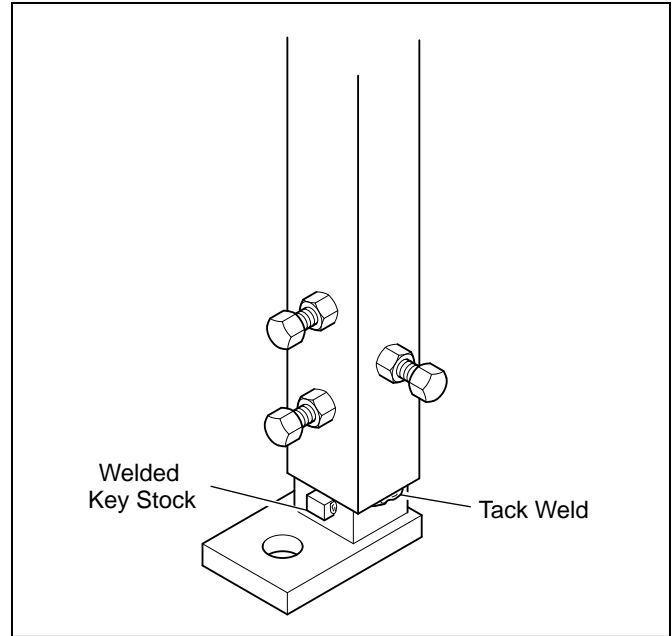

Figure 1.2 Leg Extension Adjustment

1.3 HYDRAULIC CONNECTIONS

The hydraulic manifold requires two hose assembly connections:

- Supply from the hydraulic power unit
- Fluid return to the tank

Both hose assemblies have a 1 – 11 1/2 female thread for connection to the hydraulic power supply. Route the hoses in such a way that they are not crimped, bent or touching any moving parts.

If additional hose is needed, be sure to use only hose rated for a minimum of 2,000 psi [138 bar] operating pressure. (Recommended fluid power supply pressures are 800 to 1000 psi [55 to 69 bar].)

**WARNING:**

Use only hose rated for a minimum of 2,000 psi [138 bar] operating pressure. Improperly rated hose could break, causing fluid leakage and unsafe conditions.

1.4 ELECTRICAL CONNECTIONS

Typical electrical connections include:

- Input and output connections to the system controller.
- 120 volt power connection.
- Three-phase power connections for the unloading, pallet transfer, and pallet return conveyors.

The depalleter is shipped with all its dedicated components properly wired. There are usually other connections that need to be completed before the system is operational. The electrical schematics supplied with each depalleter list the components and their respective wire numbers. Refer to these prints when performing any electrical connections.

**WARNING:**

Electrical connections from the depalleter to other conveyor components may be required. Ensure all electrical circuits are shut down and locked out before performing any electrical work.

