



# HARMONIC DEPALLETER

MODEL DP-12 • FOUR AT A TIME



**MAINTENANCE/OPERATION MANUAL**  
**466360F9702**

**JUNE 1997 • US\$250**

**BESSER** World Headquarters  
801 Johnson St. • Alpena, Michigan, 49707 • U.S.A.  
Phone (517) 354-4111

# **BESSER**

COMPANY NAME: .....

SERIAL NUMBER: .....

ASSEMBLY NUMBER: .....

WIRING DIAGRAM NUMBER: .....

INSTALLATION DRAWING NUMBER: .....

# TABLE OF CONTENTS

	<b>Page</b>
<b>LIST OF TABLES</b> .....	ii
<b>LIST OF ILLUSTRATIONS</b> .....	ii
<b>SAFETY BULLETIN</b> .....	iii
<b>SAFETY SIGNS</b> .....	iv
<b>SPECIFICATIONS</b> .....	vi
<b>SECTION 1 INTRODUCTION</b>	
1.1 OVERVIEW.....	1-1
1.1.1 Terms and Abbreviations.....	1-1
1.1.2 Depalleter Configuration.....	1-1
1.1.3 Summary of Operation.....	1-2
1.2 DESIGN CHARACTERISTICS.....	1-2
<b>SECTION 2 OPERATION</b>	
2.1 MODES OF OPERATION.....	2-1
2.1.1 Manual (Hand) Mode.....	2-1
2.1.2 Off Mode.....	2-1
2.1.3 Automatic (Auto) Mode.....	2-1
2.2 SEQUENCE OF OPERATION.....	2-2
2.2.1 Sequence of Operation.....	2-2
2.2.1.1 Initial Starting Conditions.....	2-2
2.2.1.1 Depalleter Operation.....	2-2
2.2.2 Slider Plate and Optional Turntable Operation.....	2-3
2.3 START UP PROCEDURE.....	2-4
2.4 SHUTDOWN PROCEDURES.....	2-4
2.4.1 Normal Shutdown.....	2-4
2.4.2 Emergency Shutdown.....	2-4
<b>SECTION 3 MAINTENANCE INSTRUCTIONS</b>	
3.1 GENERAL.....	3-1
3.2 SERVICE SCHEDULE.....	3-1
3.3 LUBRICATION SCHEDULE.....	3-2
3.4 PERIODIC INSPECTION.....	3-3
3.5 ADJUSTMENTS.....	3-4
3.5.1 Depalleter Adjustments.....	3-4
3.5.1.1 Depalleter/Extension Plate Height.....	3-4
3.5.1.2 Pusher Plate/Product Contact Angle.....	3-5
3.5.2 Sensor Adjustments.....	3-6
3.5.3 Speed Adjustments.....	3-7
3.5.4 Turntable Adjustments.....	3-8
3.5.4.1 Turntable Plate Height.....	3-8
3.5.4.2 Sensor Position.....	3-8
3.5.4.3 Hydraulic Speed.....	3-8
<b>SECTION 4 TROUBLESHOOTING</b>	
4.1 Troubleshooting Tables.....	4-1

## LIST OF TABLES

	<b>Page</b>
3-1 Service Schedule .....	3-1
3-2 Lubrication Schedule .....	3-2
4-1 General Electrical Troubleshooting .....	4-1
4-2 Depalleter Troubleshooting .....	4-3
4-3 Turntable Troubleshooting .....	4-5
4-4 Device Input/Output .....	4-6

















## LIST OF ILLUSTRATIONS

	<b>Page</b>
1-1 Harmonic Depalleter, Pallet Straight Thru Orientation and Component Location.....	1-1
2-1 Remote Control Station.....	2-1
2-2 Double-Push Depalleter .....	2-3
3-1 Lubrication Points, Depalleter .....	3-2
3-2 Lubrication Points, Turntable .....	3-3
3-3 Depalleter Height Adjustment .....	3-4
3-4 Angular Adjustment for the Pusher Plate.....	3-5
3-5 Sensor Locations, Pallet Straight Thru Orientation .....	3-6
3-6 Hydraulic Flow Controls .....	3-7
3-7 Turntable Adjustments.....	3-8

## SAFETY BULLETIN

This notice is issued to advise you that some previously accepted shop practices may not be keeping up with changing Federal and State Safety and Health Standards. Your current shop practices may not emphasize the need for proper precautions to insure safe operation and use of machines, tools, automatic loaders and allied equipment and/or warn against the use of certain solvents or other cleaning substances that are now considered unsafe or prohibited by law. Since many of your shop practices may not reflect current safety practices and procedures, particularly with regard to the safe operation of equipment, it is important that you review your practices to ensure compliance with Federal and State Safety and Health Standards.

**IMPORTANT: The operation of any machine or power-operated device can be extremely hazardous unless proper safety precautions are strictly observed. Observe the following safety precautions:**

-  Always be sure proper guarding is in place for all pinch, catch, shear, crush and nip points.
-  Always make sure that all personnel are clear of the equipment before starting it.
-  Always be sure the equipment is properly grounded.
-  Always turn the main electrical panel off and lock it out in accordance with published lockout/tagout procedures prior to making adjustments, repairs, and maintenance.
-  Always wear appropriate protective equipment like safety glasses, safety shoes, hearing protection and hard hats.
-  Always keep chemical and flammable material away from electrical or operating equipment.
-  Always maintain a safe work area that is free from slipping and tripping hazards.
-  Always be sure appropriate safety devices are used when providing maintenance and repairs to all equipment.
-  Never exceed the rated capacity of a machine or tool.
-  Never modify machinery in any way without prior written approval of the Besser Engineering Department.
-  Never operate equipment unless proper maintenance has been regularly performed.
-  Never operate any equipment if unusual or excessive noise or vibration occurs.
-  Never operate any equipment while any part of the body is in the proximity of potentially hazardous areas.
-  Never use any toxic flammable substance as a solvent cleaner.
-  Never allow the operation or repair of equipment by untrained personnel.
-  Never climb or stand on equipment when it is operational.

It is important that you review Federal and State Safety and Health Standards on a continual basis. All shop supervisors, maintenance personnel, machine operators, tool operators, and any other person involved in the setup, operation, maintenance, repair or adjustment of Besser-built equipment should read and understand this bulletin and Federal and State Safety and Health Standards on which this bulletin is based.

## SAFETY SIGNS

Sign	Description	Required
1	Electric Motor .....	1
2	All Machines.....	1
	All Panels .....	1
3	Mixer .....	4
4	Block Machine.....	1
	SF-7 Cuber .....	8
	BTO-6.....	2
	Overhead Block Transfer .....	3
	Depalleter.....	2
	AF-7 Block Pusher .....	2
5	Concrete Products Machine.....	1
6	Concrete Products Machine.....	1
7	Concrete Products Machine.....	2
8	Besser-Matic .....	4
9	Besser-Matic .....	4
10	Pallet Transport System .....	4
11	LSC-40 .....	4
	Overhead Block Transfer .....	4
12	Conveyors .....	6
13	SF-7 Cuber .....	8
14	AF-7 Block Pusher .....	2
	Pallet Transport System .....	4
15	All Machines.....	1
	All Panels .....	1
16	SF-7 Cuber .....	3
	AF-7 Block Pusher .....	2
	Slat Conveyors.....	2

**To order safety decals, contact your local Besser representative  
or the Besser Central Order Department.**

**Thank you!**

<p>1</p> <p>High voltage. Follow lockout procedure before servicing panel or machine.</p>	<p>2</p> <p>High voltage. Follow lockout procedure before servicing panel or machine.</p>	<p>3</p> <p>Mixer blade hazard. Close front panel and stay clear during operation. Follow lockout procedure before servicing.</p>	<p>4</p> <p>Crush hazards. Stay clear of car and crawler. Follow lockout procedure before servicing.</p>
<p>5</p> <p>Crush hazards. Stay clear of machine. Follow lockout procedure before servicing.</p>	<p>6</p> <p>Crush hazards. Stay clear of machine. Follow lockout procedure before servicing.</p>	<p>7</p> <p>Crush and pinch-points. Stay clear of machine. Follow lockout procedure before servicing.</p>	<p>8</p> <p>Crush hazards. Stay clear of transfer area. Follow lockout procedure before servicing.</p>
<p>9</p> <p>Falling objects. Stay clear of transfer area. Follow lockout procedure before servicing.</p>	<p>10</p> <p>Crush hazards. Stay clear of car and crawler. Follow lockout procedure before servicing.</p>	<p>11</p> <p>Crush hazard. Stay clear of machine. Follow lockout procedure before servicing.</p>	<p>12</p> <p>Nip hazard. Stay clear of conveyor. Follow lockout procedure before servicing.</p>
<p>13</p> <p>Crush hazard. Follow lockout procedure and secure elevator before servicing.</p>	<p>14</p> <p>Crush hazard. Stay clear of transfer area. Follow lockout procedure before servicing.</p>	<p>15</p> <p>SAFETY INSTRUCTIONS INSTRUCCIONES DE SEGURIDAD</p> <p>SUGGESTED LOCKOUT PROCEDURE</p> <ol style="list-style-type: none"> <li>1. Announce lockout to other employees.</li> <li>2. Turn power off at main panel.</li> <li>3. Lockout power in off position.</li> <li>4. Put key in pocket.</li> <li>5. Clear machine of all personnel.</li> <li>6. Test lockout by hitting run button.</li> <li>7. Block, chain or release stored energy sources.</li> <li>8. Clear machine of personnel before</li> </ol>	<p>16</p> <p>Crush and pinch-points. Stay off conveyor. Follow lockout procedure before servicing.</p>

### SAFETY SIGNS

## HARMONIC DEPALLETER SPECIFICATIONS

### DEPALLETER

Double push harmonic-style, crank arm hydraulic depalleter, with UP/DOWN pusher

<b>TOTAL WEIGHT:</b>	2,000 pounds [907.2 Kg]
<b>MINIMUM HYDRAULIC PRESSURE:</b>	850 psi [58 bar]
<b>MACHINE SPEED:</b>	
RECOMMENDED:	10 cycles per minute
MAXIMUM:	12 cycles per minute
<b>PRODUCTION CAPACITY:</b>	Strips any concrete product up to 12 inches [305 mm] high from pallet
<b>OIL REQUIREMENTS:</b>	12 gpm total [56.7 lpm], 6 gpm crank motor [22.7 lpm], 12 gpm pusher cylinder [45.4 lpm]

**Note:**

The above gpm recommendations are for use with a block machine cycle rate of 10 or less. For a faster cycle rate, more capacity (gpm) are required. Use Shell Tellus 46 oil (or equivalent).

### TURNTABLE

Hydraulic chain-style turntable

<b>TOTAL WEIGHT:</b>	500 pounds [226.8 Kg]
<b>MACHINE SPEED:</b>	
RECOMMENDED:	10 cycles per minute
MAXIMUM:	12 cycles per minute
<b>PRODUCTION CAPACITY:</b>	Any concrete product up to 12 inches [305 mm] high on a standard pallet
<b>OIL REQUIREMENTS:</b>	5 gpm total (18.9 lpm). Use Shell Tellus 46 oil [or equivalent]
<b>OPERATING CONDITIONS:</b>	Besser machinery and equipment is designed to comply with the essential health and safety regulations (EHSR) that apply to directives which are applicable to an industrial environment. Buyer shall utilize this equipment in a manner consistent with its design and only in an industrial environment.
<b>OPERATING RANGES:</b>	Here are the normal operating ranges for machine sensors (limit, proximity) and control devices contained within the control panels.
<b>Ambient operating temperature range:</b>	32° to 131°F [0° to 55°C]
<b>Humidity range:</b>	5 to 95% (non-condensing)
<b>Line voltage:</b>	85 to 132 volts – AC 50/60 Hz

# SECTION 1 INTRODUCTION

## 1.1 OVERVIEW

The harmonic depalleter removes the cured product from steel manufacturing pallets. The machine is called a “harmonic depalleter” because the speed of its pusher plate varies during the depalleting process, moving product off each pallet in a gentle but efficient manner. Refer to Section 1.1.3 for a detailed summary of operation.

### 1.1.1 Terms and Abbreviations

The following terms and abbreviations are used throughout this manual.

- ACR Auto Control Relay
- bar Unit of Pressure
- CB Circuit Breaker
- DEP Depalleter
- gpm Gallons Per Minute
- lpm Liters Per Minute

- LS Limit Switch
- PER Photoelectric Cell
- PRS Proximity Sensor
- psi Pounds Per Square Inch
- UC Unloading Conveyor
- vac Volts, Alternating Current

### 1.1.2 Depalleter Configuration

The depalleter can be purchased in two models:

- Single Push
- Double Push

Both models operate in a Pallet Straight Thru orientation. In this orientation, the loaded pallet enters the depalleter from the side. Product is pushed off the pallet either to the left or right. The empty pallet continues straight through the depalleter, down the unloading conveyor to the pallet return conveyor. Refer to Figure 1.1.

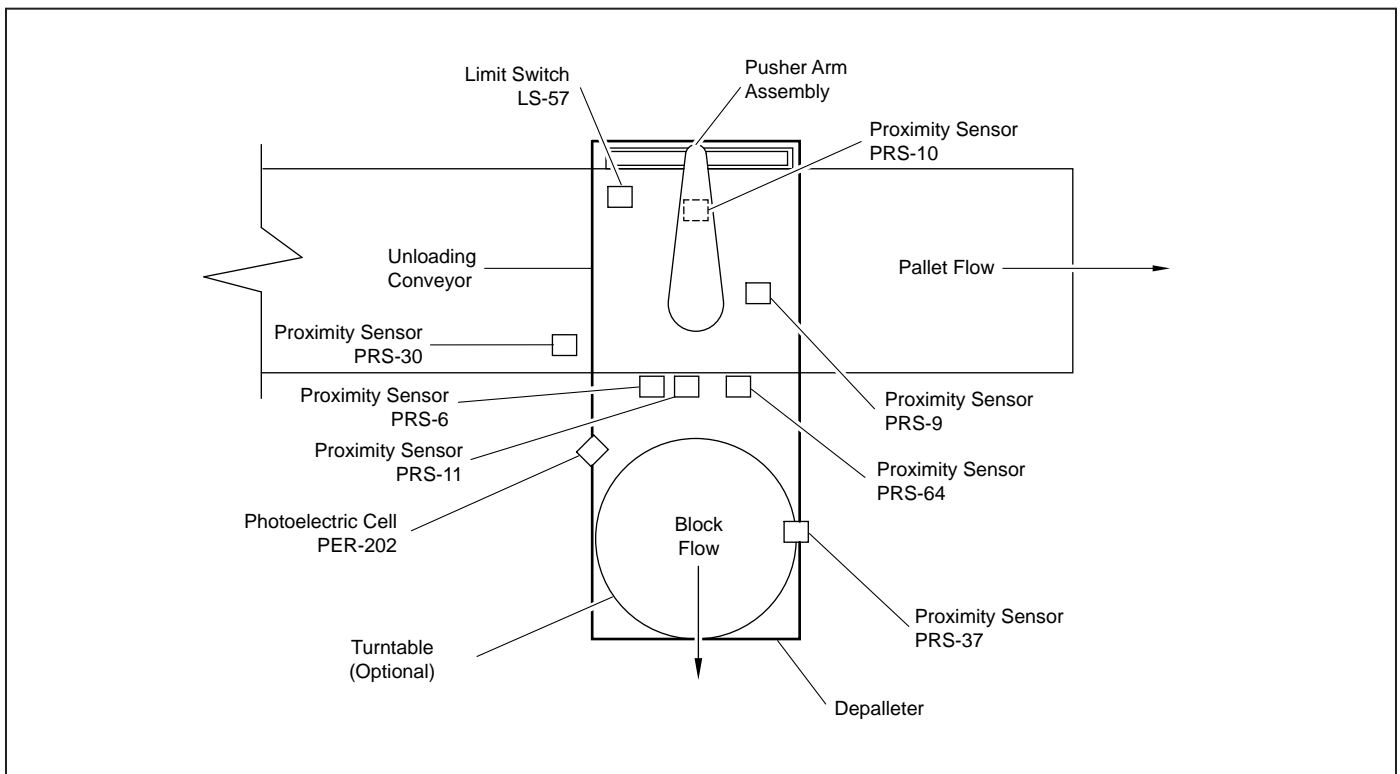

**Figure 1.1** Harmonic Depalleter, Pallet Straight Thru Orientation & Component Location

### 1.1.3 Summary of Operation

The harmonic depalleter operates as follows:

1. Cured, palletted product moves into the harmonic depalleter from the unloading conveyor.
2. The pusher plate begins its motion slowly so that it gently contacts the incoming product.
3. As the product begins to move, pusher plate speed gradually increases.
4. When the pusher plate nears its full forward position, it slows down once again to ensure smooth product release.
5. The pusher plate speeds up as it returns to its starting position.
6. The empty pallet is ejected onto the pallet return conveyor.
7. The cycle repeats.

### 1.2 DESIGN CHARACTERISTICS

The harmonic depalleter is made of a heavy-duty welded steel frame that provides mounting capabilities for the following components:

- Single or Double Push mechanism with harmonic crank arm to remove concrete products from the pallet.
- Hydraulic motor, cylinder and controls to operate the pusher mechanism.
- Photoelectric cell, proximity sensors and limit switches to monitor the movement of pallets and components.
- Remote control station for operating the depalleter during setup, maintenance or troubleshooting.
- Optional turntable mechanism that rotates 90 degrees per depalleter cycle. The turntable is mounted inside the depalleter and includes a hydraulic motor and controls.

## SECTION 2 OPERATION

### 2.1 MODES OF OPERATION

The depalleter switch on the Remote Control Station allows you to select and change the depalleter's current mode of operation. There are three selections available: hand, off, and auto. Place the depalleter switch in the desired position. See figure 2.1.

#### 2.1.1 Manual (HAND) Mode

Select the hand mode to manually control depalleter operation. This mode allows you to control most depalleter functions for setup, maintenance, or troubleshooting purposes.

Manually-controlled operations include:

- Depalleter Forward
- Depalleter Reverse
- Pusher Up
- Pusher Down
- Pallet Transfer Conveyor Forward
- Pallet Transfer Conveyor Reverse (if hydraulic)

The depalleter pusher and pallet transfer joysticks allow you to control these operations.

#### 2.1.2 Off Mode

Place the depalleter switch in the off position to turn off power to the depalleter machine and shut down all operations of the depalleter and unloading conveyors.

#### 2.1.3 Automatic (AUTO) Mode

Select the automatic mode for normal production cycling. In this mode, the system controls all depalleter operations. While in automatic mode, loaded pallets automatically move into and out of the depalleter. Refer to Section 2.2 for more information on auto mode sequence.

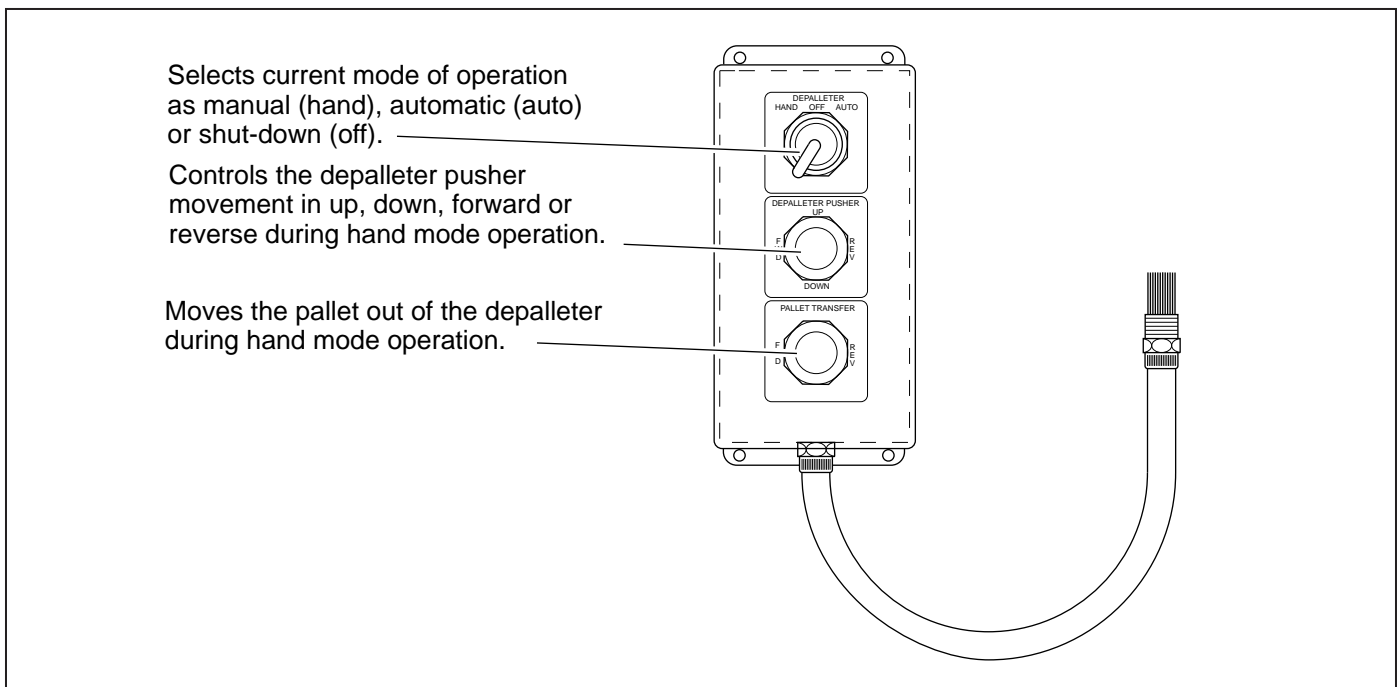

**Figure 2.1** Remote Control Station

## 2.2 SEQUENCE OF OPERATION

This section explains the sequence of auto mode operation for the harmonic depalleter. As previously mentioned, the auto mode automatically controls all depalleter operations for normal production cycling. To activate the auto mode, place the Remote Control Station depalleter switch in the auto position.

### 2.2.1 Sequence of Operation

This section outlines the operation sequence for the harmonic depalleter. Section 1, Figure 1.1, includes a depalleter diagram that identifies the location of the proximity sensors, limit switches and photoeye.

#### 2.2.1.1 Initial Starting Conditions

1. Depalleter and pallet return switch to on position.
2. Depalleter hand-off-auto switch to auto position.
3. Depalleter pusher travels to home position.
4. Depalleter pusher travels to down position.
5. Pallet transfer conveyor travels to home position.
6. **For depalleters equipped with block turnover:** If so-equipped, the block turnover mechanism travels to home position.
7. **For depalleters equipped with the optional turntable:** Turntable rotates to home position.

#### 2.2.1.2 Depalleter Operation

1. Palletized product enters depalleter.
2. PER-202 senses concrete product on the pallet.
3. Unloading conveyor 2 stops momentarily.
4. Next pallet trips PRS-30.
5. Unloading conveyor 1 stops momentarily.
6. Crank arm rotates clockwise (as viewed from above) and moves pusher assembly forward.
7. Pusher strips product from pallet.
8. Crank arm trips PRS-64.
9. Unloading conveyor 2 re-starts.
10. Unloading conveyor 1 re-starts.
11. Crank arm trips PRS-11.
12. Pusher begins to raise.
13. Crank arm releases PRS-11.
14. Depalleter pusher to fully raised position.
15. Crank arm continues to rotate.
16. For depalleters equipped with the optional turntable: Turntable rotates.
17. For depalleters equipped with the optional turntable: Turntable stops.
18. Crank arm returns to home position and stops.
19. Pusher begins downward motion.
20. The entire cycle repeats.

### 2.2.2 Slider Plate and Optional Turntable Operation (Double Push Model Only)

The double push depalletter typically uses a slider plate or optional turntable. (Refer to Figure 2.2.)

- **Operation with optional turntable:** Pusher plate "A" moves the product off of the turntable at the same time pusher plate "B" moves the product off of the pallet and onto the turntable.

- **Operation with slider plate:** Pusher plate "A" moves the product off of the slider plate at the same time pusher plate "B" moves the product off of the pallet and onto the slider plate.

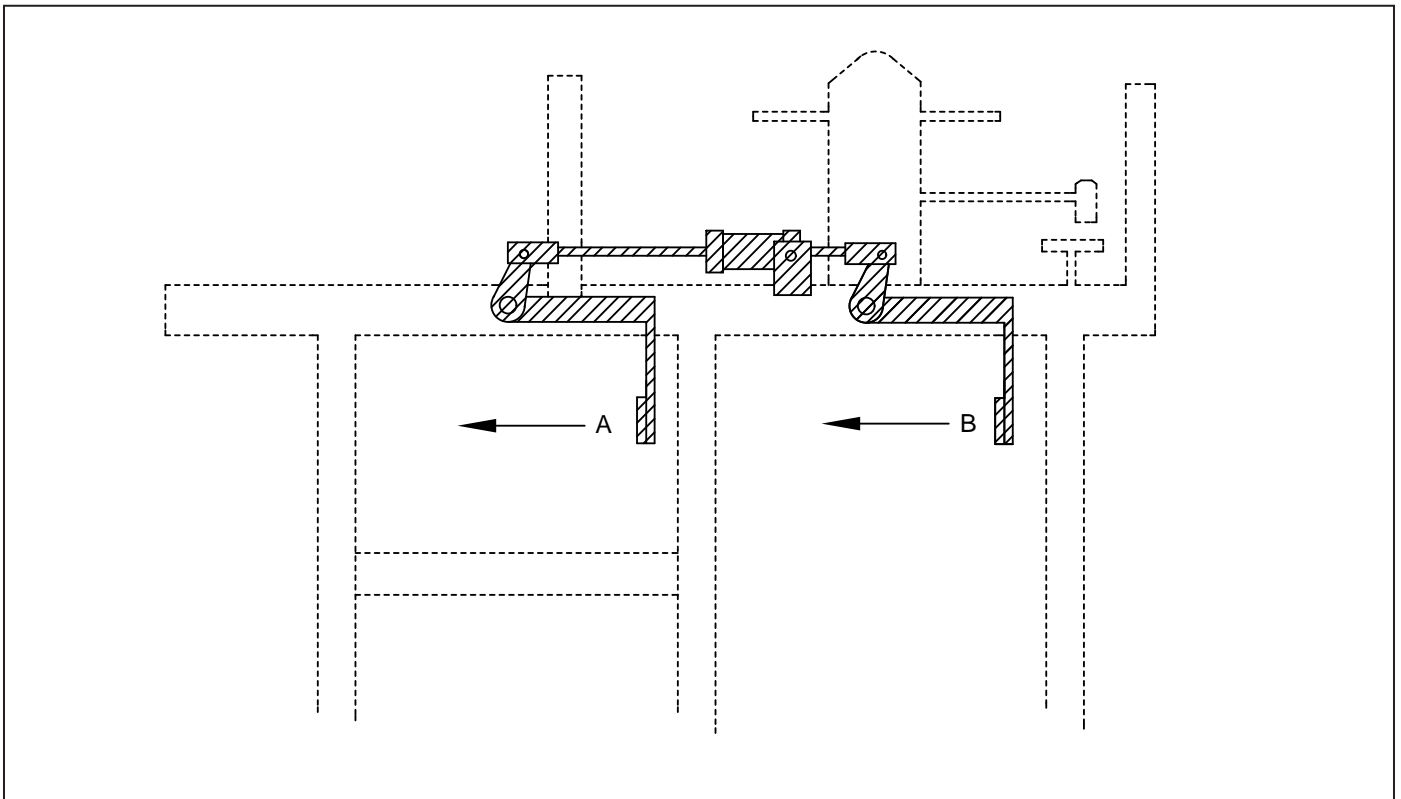

**Figure 2.2** Double-Push Depalletter

## 2.3 START-UP PROCEDURE

Before starting the depalleter, walk around the machine and perform a thorough visual inspection. Ensure there are no pallets in the depalleter and that the pusher arm is in its home position (down and back).

When the depalleter is clean and ready for use, refer to the following procedure to start the machine:

1. Place the dep & pal/ret off/on switch, located on the graphic control station, in the on position.
2. Place the hand-off-auto switch on the remote control station in the:
  - auto position (to run the depalleter in the automatic mode), or
  - hand position (to run the depalleter in manual mode).
3. Configure the unloading conveyor to run in manual or automatic mode, depending on the depalleter mode selected in Step 2. Turn on the unloading conveyor system to begin transferring loaded pallets to the depalleter.
4. Follow the sequence of operation as described in Section 2.2 for automatic mode, or use the manual mode.

## 2.4 SHUT-DOWN PROCEDURES

There are separate procedures for normal and emergency depalleter shut-down.

### 2.4.1 Normal Shut-down

The normal shut-down procedure for the harmonic depalleter is as follows:

1. When the last loaded pallet has been transferred to the depalleter, turn off the unloading conveyor that supplies loaded pallets.
2. Place the hand-off-auto switch on the remote control station in the off position.
3. Place the dep & pal ret off/on switch located on the graphic control station in the off position.

### 2.4.2 Emergency Shut-down

To shut down the depalleter in the event of an emergency situation, press the E-STOP button on the Besser-Matic Graphic Control Station.

## SECTION 3

# MAINTENANCE INSTRUCTIONS

### 3.1 GENERAL

This section highlights important service and maintenance procedures required to maximize the depalleter's operating life and ensure optimum performance. Major topics include:

- 3.2 Service Schedule
- 3.3 Lubrication Schedule
- 3.4 Periodic Inspection
- 3.5 Adjustments

### 3.2 SERVICE SCHEDULE

Table 3.1 shows the service schedule for the harmonic depalleter. The table lists:

- Items requiring service
- The type of service required
- Recommended service intervals

**Table 3.1 Service Schedule**

Item Description	Service	Interval (Operating Days)
Guards & Safety Signs	Inspection	1
Electrical Conduit	Inspection	1
Hydraulic Lines	Inspection	1
Proximity Sensors	Inspection and adjustment (if necessary)	5
Limit Switches	Inspection and adjustment (if necessary)	5
Pusher Plate	Angular contact inspection and adjustment (if necessary)	5
Extension Plate Height (Depalleter and Turntable)	Inspection and adjustment	5
Flanged Cartridges (Depalleter and Turntable)	Lubrication	30
Hydraulic Cylinder Pivot Brackets and Clevis Pin	Lubrication	30
Cam Followers	Lubrication	30
Camrol Bearings	Lubrication	30

### 3.3 LUBRICATION SCHEDULE

Regularly lubricating the depalletter's moving parts is required to maintain optimum performance. Table 3.2 identifies all depalletter and optional turntable lubrication points. Figure 3.1 shows the location of these lubrication points. Figure 3.2 shows the lubrication points for the optional turntable.

**NOTE:**

Besser recommends that you grease all lubrication points at 80-hour intervals. Use Mobilux EP#1 lubricant (or equivalent).

*Table 3-2. Lubrication Schedule*

**Depalleter**

- Flange Cartridges, Crank Arm Shaft (A)
- Flange Cartridges, Pusher Pivot Arm (B)
- Hydraulic Cylinder Pivot Brackets (C)
- Hydraulic Cylinder Clevis Pin (D)
- Cam Follower, Crank Arm (E)
- Camrol Bearings (F)

**Turntable**

- Flange Cartridges, Turntable Shaft (A)

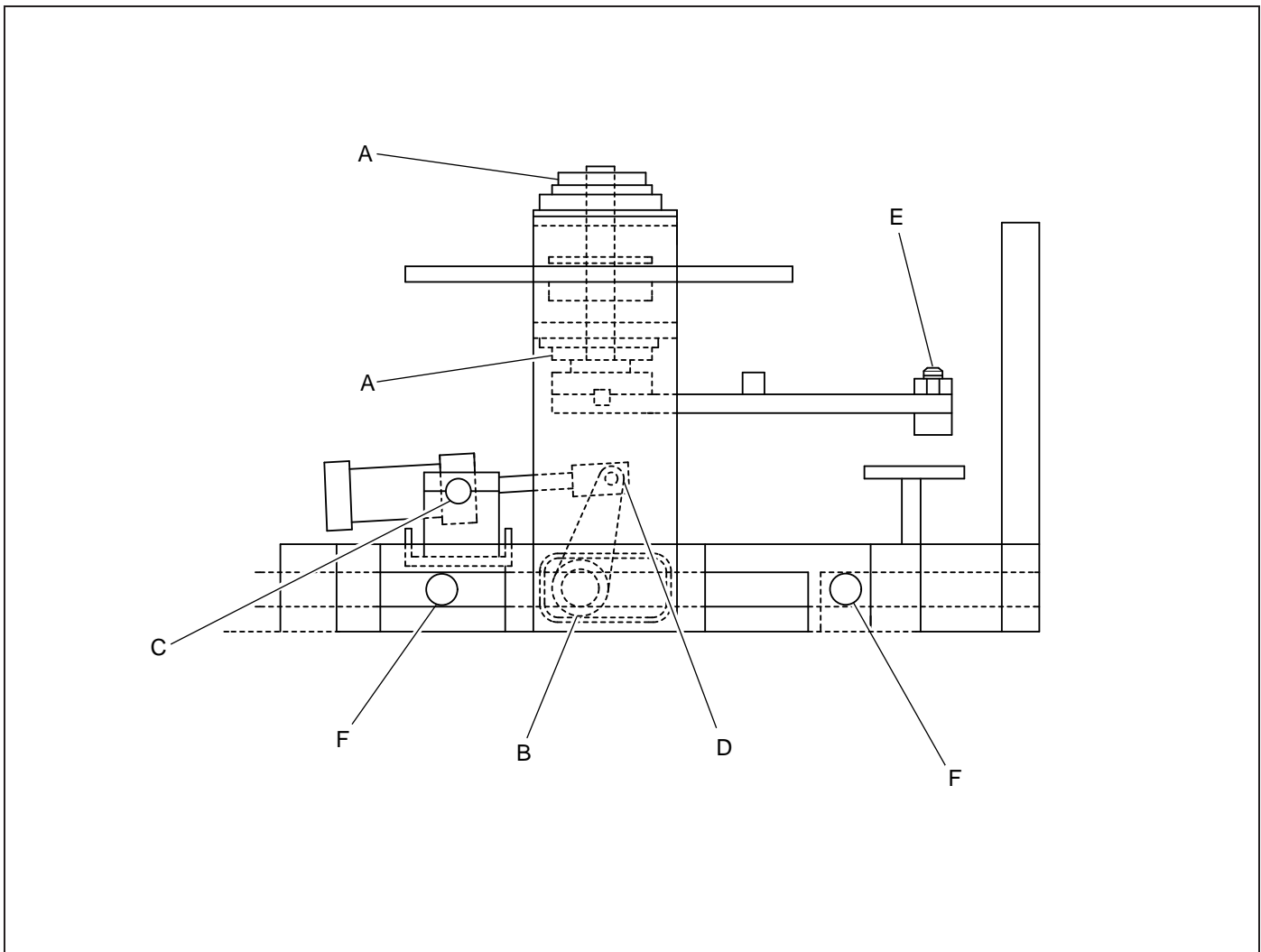

**Figure 3.1** Lubrication Points, Depalleter

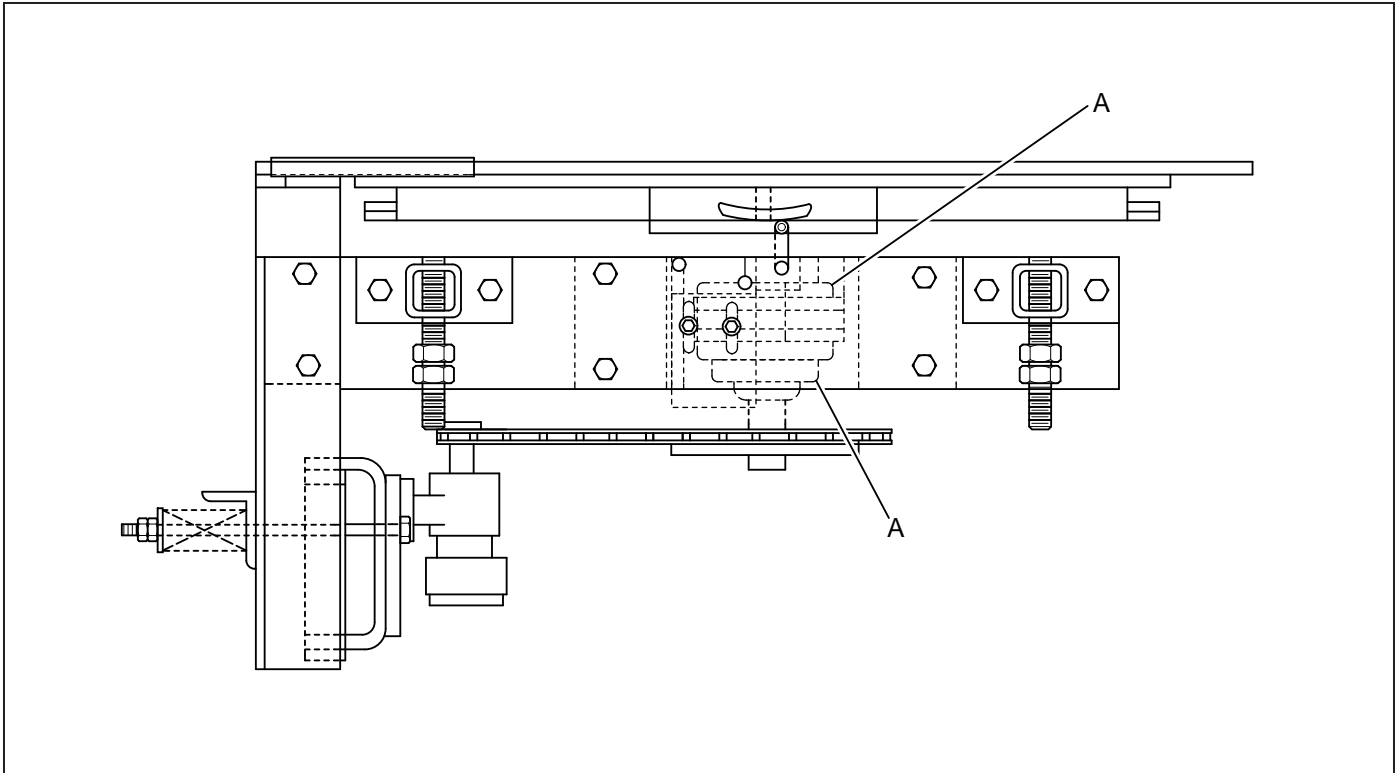
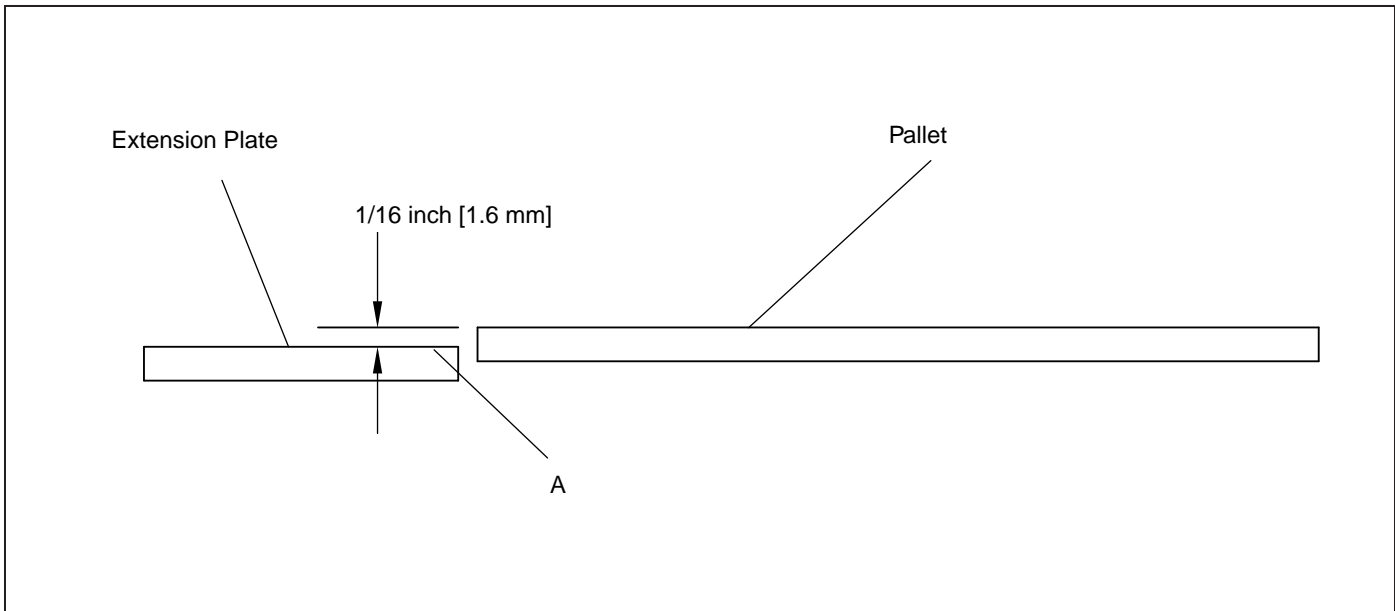

**Figure 3.2** Lubrication Points, Turntable

**3.4 PERIODIC INSPECTION**

In addition to lubricating the depalleter at regular intervals, inspect the machine often. Periodic inspection consists of the following steps:

1. Before starting the depalleter, walk around the equipment and ensure it is free of dirt buildup, rags, tools and scrap.
2. Visually inspect all electrical conduit for loose connections.
3. Visually inspect all hydraulic lines for damage to fittings, hoses or connections.
4. Visually inspect guards and safety signs. They should be attached and readable.
5. When the depalleter begins operation, observe the movement of full and empty pallets through the depalleter. Also, ensure the depalleter smoothly moves product onto the extension plate or optional turntable. Refer to section 3.5.3 if adjustments are required.
6. When the depalleter begins to operate, ensure that the turntable operates smoothly. Refer to section 3.5.4 if adjustments are required.



**Figure 3.3** Depalleter Height Adjustment

### 3.5 ADJUSTMENTS

If your periodic inspection indicates the need to adjust certain components of the harmonic depalleter or optional turntable, refer to the following adjustment procedures:

- 3.5.1 Depalleter Adjustments
- 3.5.2 Sensor Adjustments
- 3.5.3 Speed Adjustments
- 3.5.4 Turntable Adjustments

#### 3.5.1 Depalleter Adjustments

You may need to perform one or more of these depalleter adjustments periodically to compensate for normal wear.

##### 3.5.1.1 Depalleter/Extension Plate Height

This procedure adjusts the depalleter with reference to the extension plate.

1. Obtain a clean, level pallet and rest it on the unloading conveyor chain, pallet return conveyor rollers or depalleter table rollers (depending on depalleter model).
2. Adjust depalleter leg extensions to obtain a 1/16 inch [1.6 mm] drop between the top of the pallet and the top of the extension plate. Refer to Figure 3.3.
3. After leveling the depalleter and obtaining the proper height weld the leg extensions and anchor them to the floor with 3/4 inch [19 mm] anchor bolts.
4. If further leveling is necessary, you can insert shims under the extension plates to obtain the 1/16 inch [1.6 mm] height difference.

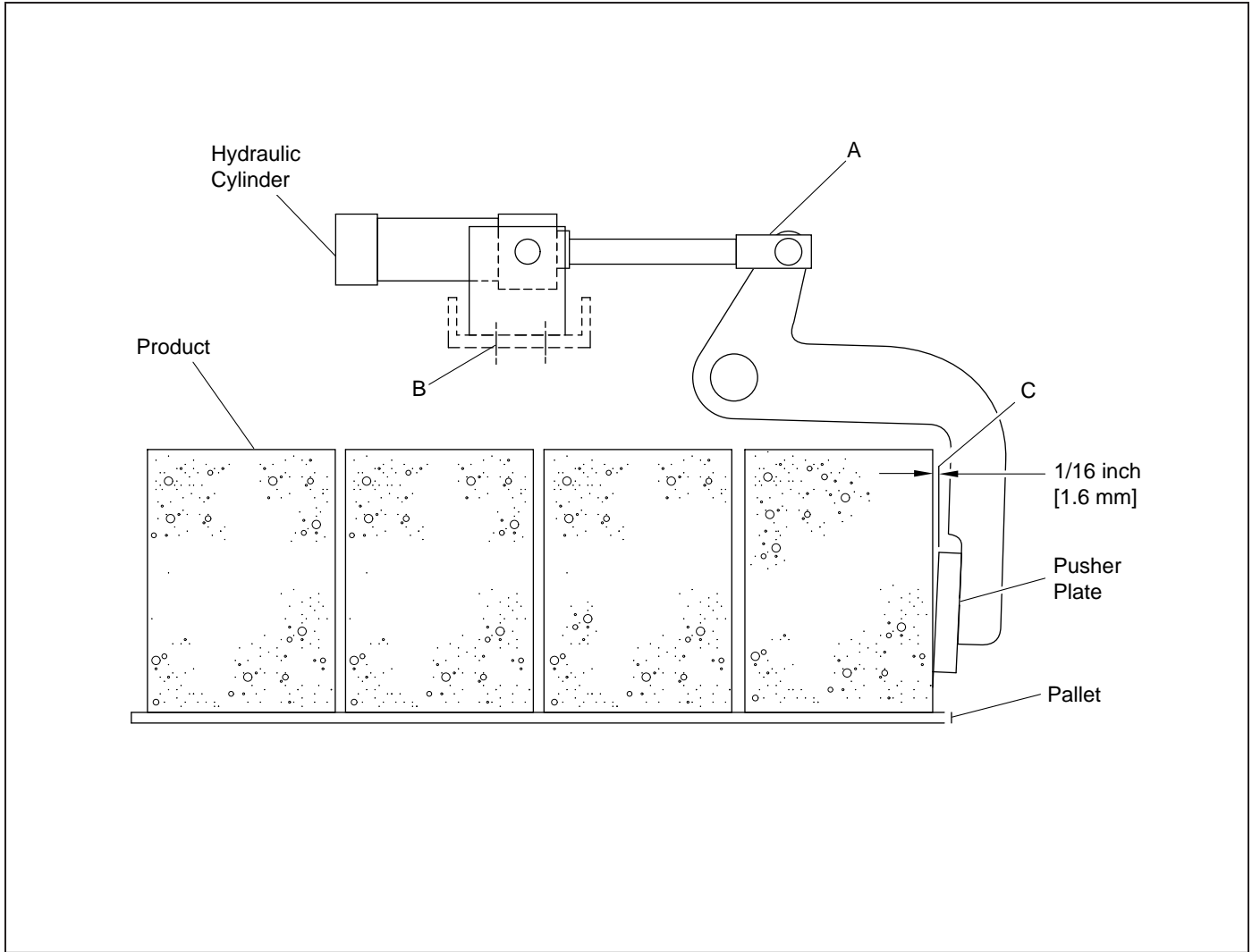

**Figure 3.4** Angular Adjustment for the Pusher Plate

**3.5.1.2 Pusher Plate/Product Contact Angle**

There must be a slight gap at the top of the pusher plate where it contacts the block as shown in Figure 3.4. This ensures proper contact, preventing the product from tipping forward and minimizing damage.

Refer to the following procedure to adjust the contact angle:

1. Place the pusher plate in the down position.
2. Extend the hydraulic cylinder as shown in Figure 3.4 to point (A).
3. Adjust the cylinder mounting bracket (B) to obtain a 1/16 inch [1.6 mm] gap (C) at the top of the pusher plate.

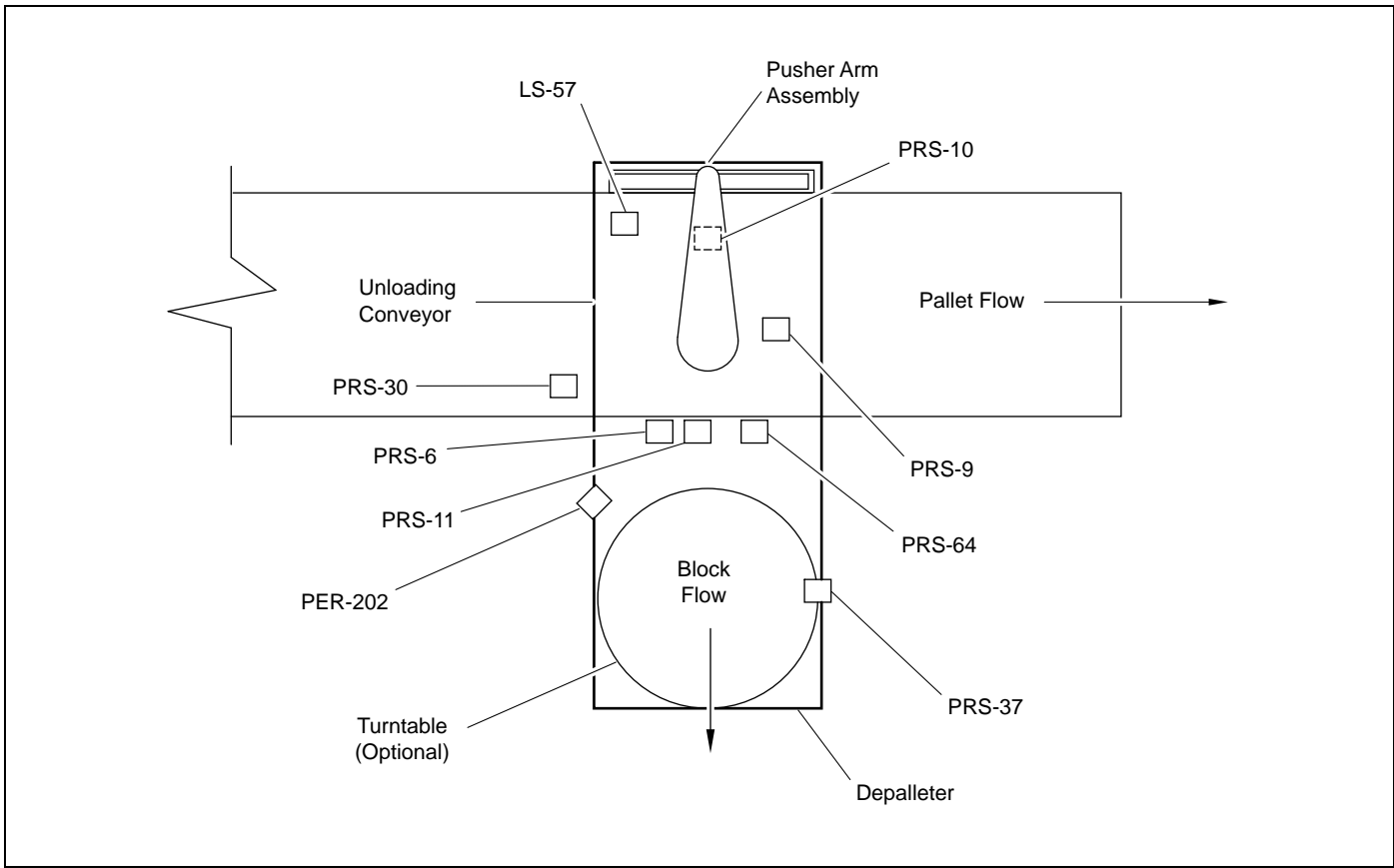

**Figure 3.5** Sensor Locations, Pallet Straight Thru Orientation

### 3.5.2 Sensor Adjustments

Inspect the proximity sensors and limit switches periodically for proper operation. Correct sensor adjustment is described below. Refer to Figure 3.5 for sensor locations.

1. Adjust PRS-9 so that it is 1/4 inch [6 mm] below the bottom of the pallet. Position the sensor so that the pallet comes to a stop at the center of the depalleter.
2. Adjust PRS-64 to restart the unloading conveyor when:
  - The product has been removed from the pallet, and
  - The pusher plate is 1 inch [25 mm] beyond the edge of the pallet.
3. Adjust PRS-11 so that the pusher plate reaches its forward-most position with the pusher plate down.
4. Adjust LS-57 so that it can be triggered in either direction. When the hydraulic cylinder is fully extended and the pusher plate is down, the switch should be triggered in a counterclockwise direction. When the hydraulic cylinder is fully retracted and the pusher plate is up, the switch should be triggered in a clockwise direction.
5. Adjust PRS-10 so that it triggers when the pusher plate reaches its farthest return position with the pusher plate up (pusher plate home position).

**3.5.3 Speed Adjustments**

The hydraulic speed must be properly adjusted to maintain optimum depalleter operating efficiency. The machine provides a hydraulic flow control adjustment for each of the three pusher plate motions: forward/reverse, up, and down.

Besser recommends a six-second cycle which breaks down as follows:

- Five seconds for a complete forward/reverse motion of the pusher assembly.
- One-half second for the up motion of the pusher plate.
- One-half second for the down motion of the pusher plate.

Refer to the following procedure to adjust pusher-plate motion speed:

1. Turn the crank arm drive flow control valve clockwise to decrease the speed and counterclockwise to increase the speed. Refer to Figure 3.6. The forward/reverse motion should be set to obtain a five-second cycle.

2. Turn the pusher plate up flow control valve clockwise to decrease the speed and counterclockwise to increase the speed. Refer to Figure 3.6.

**NOTE:**

Crank arm speed, PRS-11 position, and the up speed are all interdependent. The up speed adjustment is the key adjustment because pusher plate up motion must be fast enough to trigger LS-57 in a clockwise direction before the crank arm releases PRS-11. If the up speed is too slow, pusher plate up/down motion will be interrupted.

3. Turning the pusher plate down flow control adjustment clockwise to decrease the speed and counterclockwise to increase the speed. Adjust the pusher plate down motion so it takes one-half second to fully lower the pusher plate. Refer to Figure 3.6.

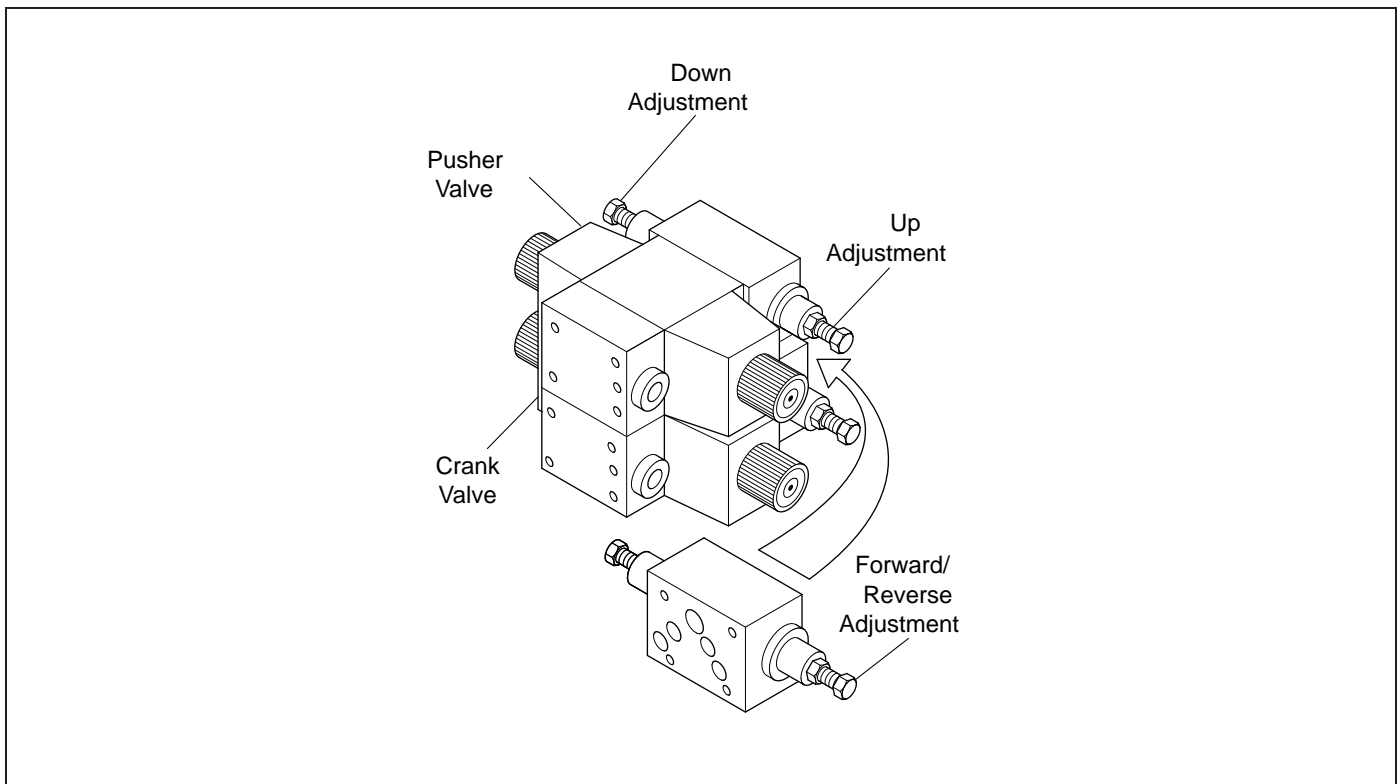

**Figure 3.6** Hydraulic Flow Controls

### 3.5.4 Turntable Adjustments

Perform these adjustments as necessary to compensate for normal wear.

#### 3.5.4.1 Turntable Plate Height

Use the following procedure to adjust the height of the turntable plates. (Figure 3.7):

1. Adjust the four mounting screws (A) that hold the turntable in the depalleter so the turntable top plate is 1/32 inch [0.8 mm] below the top of the depalleter extension plate.
2. Adjust the turntable filler plate mounting brackets so the filler plates are 1/32 inch [0.8 mm] below the top of the turntable top plate.
3. Rotate the turntable top plate 360 degrees to verify both 1/32 inch [0.8 mm] dimensions are consistent throughout the rotation of the turntable.

#### 3.5.4.2 Sensor Position

Adjust the position of PRS-37 so that it properly contacts the turntable actuators. There are four actuators, located every 90 degrees on the underside of the top plate assembly.

#### 3.5.4.3 Hydraulic Speed

**Note:**

Before performing this adjustment, ensure the depalleter cycle speed is properly set. Refer to section 3.5.3 for more information.

Observe the speed of the turntable in relation to the cycle of the depalleter. The turntable should complete its 90-degree rotation just before the depalleter reaches its home position.

- If the turntable operates too fast, the product may slip out of position or the actuators may not stop on PRS-37.
- If the turntable is too slow, it will not complete its 90 degree turn before the depalleter reaches its home position. This will interrupt the depalleter cycle.

To adjust the rotational speed of the turntable, turn the hydraulic control:

- Clockwise to increase the speed, or
- Counterclockwise to decrease the speed

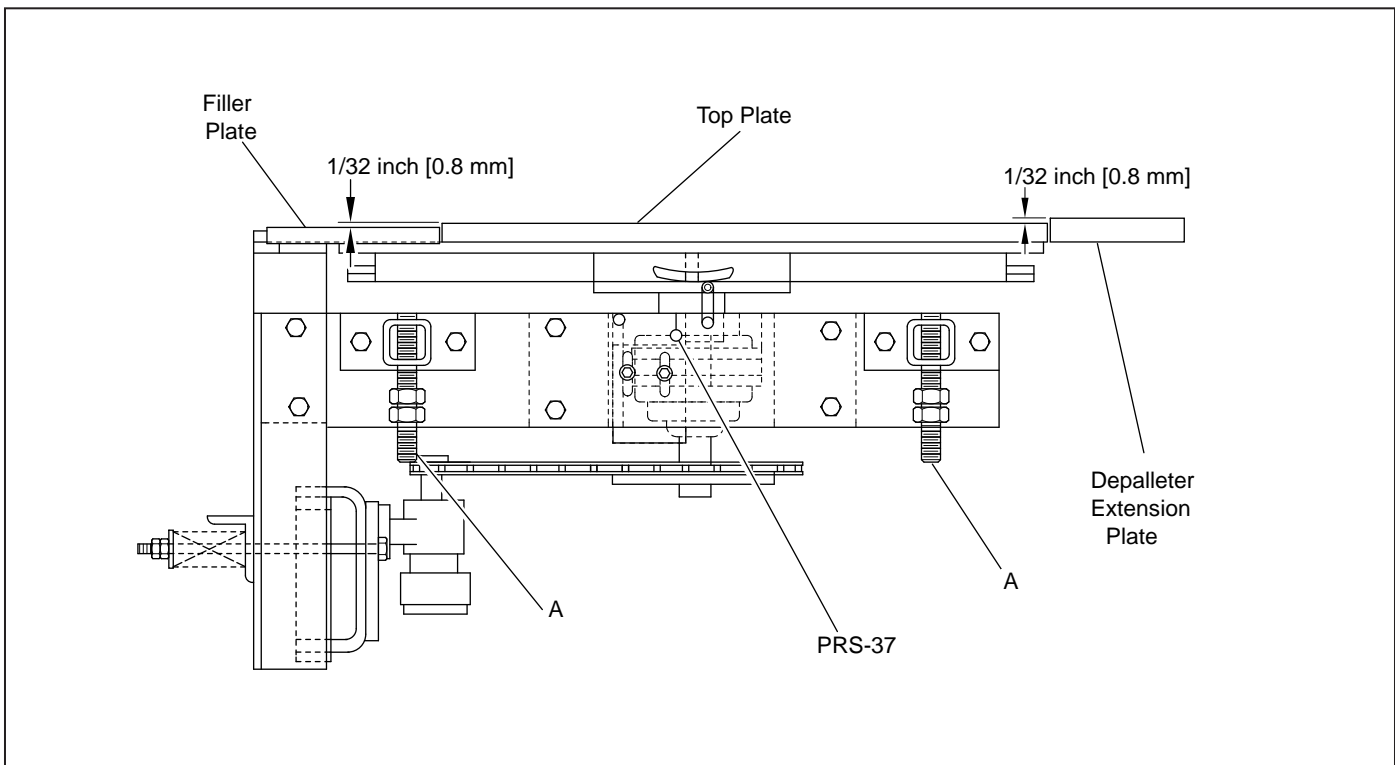

Figure 3.7 Turntable Adjustments

# SECTION 4

## TROUBLESHOOTING

### 4.1 TROUBLESHOOTING TABLES

Potential problems exist for each system of the harmonic depalleter. The following tables will help you troubleshoot and repair such problems:

- **Table 4.1:** General Electrical Troubleshooting
- **Table 4.2:** Depalleter Troubleshooting
- **Table 4.3:** Turntable Troubleshooting
- **Table 4.4:** Device Input/Output

**Table 4.1 General Electrical Troubleshooting**

Trouble	Probable Cause	Corrective Action
A. Depalleter does not operate.	1. Dep & pallet return switch on spade control station is turned off.	1. Turn on switch.
	2. hand-off-auto switch on remote control station is placed in the off position.	2. Turn switch to the auto position to operate the depalleter in the automatic mode.
	3. Unloader is not in hand or auto position.	3. Turn Unloader switch to hand or auto.
B. Depalleter drive does not move in the forward direction.	1. Circuit breaker (120CB) is open.	1. Determine what caused circuit breaker to open, correct the condition and close the circuit breaker.
	2. Proximity Sensor (PRS-10) is not tripped.	2. Determine cause and make repair. Manually rotate crank over PRS-10.
	3. Solenoid is faulty.	3. Refer to Table 4.2, Trouble A.
	4. Limit switch (LS-57 ccw) is not tripped.	4. Determine cause and repair. Manually lower pusher.

**Table 4.1 General Electrical Troubleshooting – Continued**

<b>Trouble</b>	<b>Probable Cause</b>	<b>Corrective Action</b>
C. Pusher does not operate in the up direction.	1. Circuit breaker (121CB) is open.	1. Determine what caused circuit breaker to open, correct the condition and close the circuit breaker.
	2. Solenoid is faulty.	2. Refer to Table 4.2, Trouble A.
D. Pusher does not operate in the down direction.	1. Circuit breaker (122CB) is open.	1. Determine what caused circuit breaker to open, correct the condition and close the circuit breaker.
	2. Solenoid is faulty.	2. Refer to Table 4.2, Trouble A.
E. Pallet transfer conveyor does not operate in the forward direction.	1. Circuit breaker (124CB) is open.	1. Determine what caused circuit breaker to open, correct the condition and close the circuit breaker.
	2. Solenoid is faulty.	2. Refer to Table 4.2, Trouble A.

**Table 4.2 Depalleter Troubleshooting**

<b>Trouble</b>	<b>Probable Cause</b>	<b>Corrective Action</b>
A. A given hydraulic solenoid valve fails to open during operation.	<ol style="list-style-type: none"> <li>1. Wiring between controller and solenoid valve is faulty.</li> <li>2. Solenoid is faulty.</li> </ol>	<ol style="list-style-type: none"> <li>1. Repair or replace faulty wiring.</li> <li>2. Repair or replace faulty solenoid.</li> </ol>
B. Hydraulic pump does not operate.	<ol style="list-style-type: none"> <li>1. Hydraulic reservoir is low.</li> </ol>	<ol style="list-style-type: none"> <li>1. Refill reservoir with hydraulic fluid.</li> </ol>
C. Hydraulic pressure is acceptable, but pusher cylinder and motor operate slowly.	<ol style="list-style-type: none"> <li>1. Check valve is dirty or clogged.</li> </ol>	<ol style="list-style-type: none"> <li>1. Clean, repair or replace check valve.</li> </ol>
D. Hydraulic motor for pusher operates too slowly, too fast, or not at all in a given direction.	<ol style="list-style-type: none"> <li>1. Flow control for indicated direction is closed or requires adjustment.</li> </ol>	<ol style="list-style-type: none"> <li>1. Adjust flow control as described in section 3.5.3.</li> </ol>
E. Pusher cylinder operates too slowly, too fast, or not at all in a given direction.	<ol style="list-style-type: none"> <li>1. Flow control for indicated direction is closed or requires adjustment.</li> </ol>	<ol style="list-style-type: none"> <li>1. Adjust flow control as described in section 3.5.3.</li> </ol>
F. Pallet does not come to stop in middle of the depalleter.	<ol style="list-style-type: none"> <li>1. Proximity sensor (PRS-9) requires adjustment.</li> </ol>	<ol style="list-style-type: none"> <li>1. Adjust proximity sensor as described in paragraph 3.5.2.</li> </ol>
G. Pusher plate does not move forward at the start of a cycle.	<ol style="list-style-type: none"> <li>1. Limit switch (LS-57) requires adjustment.</li> <li>2. Photocell (PER-202) requires adjustment.</li> </ol>	<ol style="list-style-type: none"> <li>1. Adjust limit switch as described in paragraph 3.5.2.</li> <li>2. Adjust photocell as described in paragraph 3.5.2.</li> </ol>
H. Unloading conveyor starts before product is removed from pallet and pusher plate has cleared the pallet.	<ol style="list-style-type: none"> <li>1. Proximity sensor (PRS-64) requires adjustment.</li> </ol>	<ol style="list-style-type: none"> <li>1. Adjust proximity sensor as described in paragraph 3.5.2.</li> </ol>

**Table 4.2 Depalleter Troubleshooting – Continued**

<b>Trouble</b>	<b>Probable Cause</b>	<b>Corrective Action</b>
I. Pusher plate raises up before it reaches its forward-most position.	1. Proximity sensor (PRS-11) requires adjustment.	1. Adjust proximity sensor as described in paragraph 3.5.2.
J. Forward and backward movement of the pusher plate is not smooth or is interrupted.	1. Limit switch (LS-57) requires adjustment.	1. Adjust limit switch as described in paragraph 3.5.2.
K. Product hangs up when being removed from pallet.	1. Extension plate requires adjustment.	1. Adjust extension plate as described in paragraph 3.5.1.1.
L. Product is damaged or tips forward when moved.	1. Pusher plate requires angular adjustment.	1. Adjust angle of pusher plate as described in paragraph 3.5.1.2.

**Table 4.3 Turntable Troubleshooting**

<b>Trouble</b>	<b>Probable Cause</b>	<b>Corrective Action</b>
A. Turntable does not operate.	1. Circuit breaker (123CB) is open.	1. Determine what caused circuit breaker to open, correct the condition and close the circuit breaker.
	2. Solenoid is faulty.	2. Refer to Table 4.2, Trouble A.
B. Turntable operates too fast or too slowly.	1. Flow control valve for turntable requires adjustment.	1. Adjust turntable flow control as described in paragraph 3.5.4.3.
C. Turntable does not stop at 90 degree intervals.	1. Turntable plate requires height adjustment.	1. Adjust height of turntable plate as described in paragraph 3.5.4.1.
	2. Proximity sensor (PRS-37) requires adjustment.	2. Adjust proximity sensor as described in paragraph 3.5.4.2.

Table 4.4 Device Input/Output

Sequence Number	Description	Device	Input	Output
<b>A. Initial Starting Conditions</b>				
1	Depalleter and pallet return switch on.	—	—	—
2	Depalleter hand-off-auto switch in auto.	—	I:8/0	—
3	Depalleter pusher home.	PRS-10	I:8/2	—
4	Depalleter pusher down.	LS-57 ccw	I:8/5	—
5	No pallet inside of the depalleter.	PRS-9	not I:8/8	—
6	Unloading Conveyor 1 running.	UC1	—	O:9/5
7	Unloading Conveyor 2 running.	UC2	—	O:9/6
8	Unloading Conveyor 3 running.	UC3	—	O:9/7
9	Unloading Conveyor 4 running.	UC4	—	O:7/1
10	Pallet transfer conveyor home.	LS-63	I:8/12	—
11	No pallet inside transfer conveyor.	PRS-69	not I:8/13	—
12	Block turnover home (if used).	—	I:8/1	—
13	Turntable home (if used).	PRS-37	I:8/9	—
14	Block machine pallet magazine not full.	PRS-18	not I:8/7	—

Table 4.4 Device Input/Output – Continued

Sequence Number	Description	Device	Input	Output
<b>B. Sequence of Operation</b>				
1	Pallet enters depalleter.	UC1	—	O:9/5
2	Concrete product is sensed on the pallet.	PER-202	I:8/11	—
2A	Concrete is not sensed on the pallet. (If no concrete product is sensed on the pallet, Unloading Conveyor 2 will not stop and the depalleter will not cycle.)	PER-202	not I:8/11	—
3	Unloading Conveyor 2 stops.	PRS-9	I:8/8	—
4	Unloading Conveyor 1 stops when next pallet trips PRS-30.	PRS-30	I:8/10	—
5	Crank arm rotates clockwise (as viewed from above) and moves pusher assembly forward to strip units off of the pallet.	DEP FWD	—	O:9/0
6	Crank arm trips PRS-64.	PRS-64	I:8/6	—
7	Unloading Conveyor 2 restarts if Unloading Conveyor 3 is running.	UC2	—	O:9/6
8	Unloading Conveyor 1 restarts when PRS-9 pallet leaves.	UC1	not I:8/8	O:9/5
9	Crank arm trips PRS-11.	PRS-11	I:8/3	—
10	Depalleter pusher begins to raise.	PUSHER UP	—	O:9/1
11	Crank arm releases PRS-11.	PRS-11	not I:8/3	—
12	Depalleter crank arm stops if pusher is not up.	DEP FWD	—	not O:9/0
13	Depalleter pusher raises fully up.	LS-57 cw	I:8/4	—
14	Crank arm continues.	DEP FWD	—	O:9/0
15	Turntable starts (if used).	Turntable	—	O:9/3
16	Turntable stops (if used).	PRS-37	I:8/9	—
17	Depalleter crank arm stops at home.	PRS-10	I:8/2	—
18	Depalleter pusher starts down.	PUSHER DWN	—	O:9/2

