



HARMONIC DEPALLETER

MODEL DP-12 • FOUR AT A TIME



INSTALLATION MANUAL
466360F9701

JUNE 1997 • US\$250

BESSER World Headquarters
801 Johnson St. • Alpena, Michigan, 49707 • U.S.A.
Phone (517) 354-4111

BESSER

COMPANY NAME:

SERIAL NUMBER:

ASSEMBLY NUMBER:

WIRING DIAGRAM NUMBER:

INSTALLATION DRAWING NUMBER:

TABLE OF CONTENTS

	Page
LIST OF ILLUSTRATIONSi
SAFETY BULLETINii
SAFETY SIGNSiii
SPECIFICATIONSvi
SECTION 1 INTRODUCTION	
1.1 GENERAL1-1
1.2 DEPALLETER INSTALLATION1-1
1.3 PALLET SUPPORT ADJUSTMENT1-3
1.4 HYDRAULIC CONNECTIONS1-3
1.5 ELECTRICAL CONNECTIONS1-4

LIST OF ILLUSTRATIONS

















	Page
1-1 Installation1-1
1-2 Leg Extension Adjustment1-2
1-3 Pallet Support Angle1-3

SAFETY BULLETIN

This notice is issued to advise you that some previously accepted shop practices may not be keeping up with changing Federal and State Safety and Health Standards. Your current shop practices may not emphasize the need for proper precautions to insure safe operation and use of machines, tools, automatic loaders and allied equipment and/or warn against the use of certain solvents or other cleaning substances that are now considered unsafe or prohibited by law. Since many of your shop practices may not reflect current safety practices and procedures, particularly with regard to the safe operation of equipment, it is important that you review your practices to ensure compliance with Federal and State Safety and Health Standards.

IMPORTANT

The operation of any machine or power-operated device can be extremely hazardous unless proper safety precautions are strictly observed. Observe the following safety precautions:

-  Always be sure proper guarding is in place for all pinch, catch, shear, crush and nip points.
-  Always make sure that all personnel are clear of the equipment before starting it.
-  Always be sure the equipment is properly grounded.
-  Always turn the main electrical panel off and lock it out in accordance with published lockout/tagout procedures prior to making adjustments, repairs, and maintenance.
-  Always wear appropriate protective equipment like safety glasses, safety shoes, hearing protection and hard hats.
-  Always keep chemical and flammable material away from electrical or operating equipment.
-  Always maintain a safe work area that is free from slipping and tripping hazards.
-  Always be sure appropriate safety devices are used when providing maintenance and repairs to all equipment.
-  Never exceed the rated capacity of a machine or tool.
-  Never modify machinery in any way without prior written approval of the Besser Engineering Department.
-  Never operate equipment unless proper maintenance has been regularly performed.
-  Never operate any equipment if unusual or excessive noise or vibration occurs.
-  Never operate any equipment while any part of the body is in the proximity of potentially hazardous areas.
-  Never use any toxic flammable substance as a solvent cleaner.
-  Never allow the operation or repair of equipment by untrained personnel.
-  Never climb or stand on equipment when it is operational.

It is important that you review Federal and State Safety and Health Standards on a continual basis. All shop supervisors, maintenance personnel, machine operators, tool operators, and any other person involved in the setup, operation, maintenance, repair or adjustment of Besser-built equipment should read and understand this bulletin and Federal and State Safety and Health Standards on which this bulletin is based.

SAFETY SIGNS

Sign	Description	Required
1	Electric Motor	1
2	All Machines.....	1
	All Panels	1
3	Mixer	4
4	Block Machine.....	1
	SF-7 Cuber	8
	BTO-6.....	2
	Overhead Block Transfer	3
	Depalleter.....	2
	AF-7 Block Pusher	2
5	Concrete Products Machine.....	1
6	Concrete Products Machine.....	1
7	Concrete Products Machine.....	2
8	Besser-Matic	4
9	Besser-Matic	4
10	Pallet Transport System	4
11	LSC-40	4
	Overhead Block Transfer	4
12	Conveyors	6
13	SF-7 Cuber	8
14	AF-7 Block Pusher	2
	Pallet Transport System	4
15	All Machines.....	1
	All Panels	1
16	SF-7 Cuber	3
	AF-7 Block Pusher	2
	Slat Conveyors	2

**To order safety decals, contact your local Besser representative
or the Besser Central Order Department.
Thank you!**



SAFETY SIGNS

HARMONIC DEPALLETER

SPECIFICATIONS

DEPALLETER

Double push harmonic-style, crank arm hydraulic depalleter, with UP/DOWN pusher

TOTAL WEIGHT:	2,000 pounds [907.2 Kg]
MINIMUM HYDRAULIC PRESSURE:	850 psi [58 bar]
MACHINE SPEED:	
RECOMMENDED:	10 cycles per minute
MAXIMUM:	12 cycles per minute
PRODUCTION CAPACITY:	Strips any concrete product up to 12 inches [305 mm] high from pallet
OIL REQUIREMENTS:	12 gpm total [56.7 lpm], 6 gpm crank motor [22.7 lpm], 12 gpm pusher cylinder [45.4 lpm]

Note:

The above gpm recommendations are for use with a block machine cycle rate of 10 or less. For a faster cycle rate, more capacity (gpm) are required. Use Shell Tellus 46 oil (or equivalent).

TURNTABLE

Hydraulic chain-style turntable

TOTAL WEIGHT:	500 pounds [226.8 Kg]
MACHINE SPEED:	
RECOMMENDED:	10 cycles per minute
MAXIMUM:	12 cycles per minute
PRODUCTION CAPACITY:	Any concrete product up to 12 inches [305 mm] high on a standard pallet
OIL REQUIREMENTS:	5 gpm total [18.9 lpm]. Use Shell Tellus 46 oil (or equivalent)
OPERATING CONDITIONS:	Besser machinery and equipment is designed to comply with the essential health and safety regulations (EHSR) that apply to directives which are applicable to an industrial environment. Buyer shall utilize this equipment in a manner consistent with its design and only in an industrial environment.
OPERATING RANGES:	Here are the normal operating ranges for machine sensors (limit, proximity) and control devices contained within the control panels.
Ambient operating temperature range:	32° to 131°F [0° to 55°C]
Humidity range:	5 to 95% (non-condensing)
Line voltage:	85 to 132 volts – AC 50/60 Hz

SECTION 1

INSTALLATION

1.1 GENERAL

The depalleter is assembled, tested, and adjusted at the factory. This reduces the installation procedures to those listed below:

- 1.2 Depalleter Installation
- 1.3 Pallet Support Adjustment
- 1.4 Hydraulic Connections
- 1.5 Electrical Connections

1.2 DEPALLETER INSTALLATION

Follow this procedure to properly install the depalleter in relation to the conveyor.

1. Secure the depalleter to a forklift or other lifting device.

2. Move the depalleter to the desired position. Verify that the depalleter is in the proper orientation to the conveyor.
3. Place an empty pallet on the conveyor. Adjust the depalleter up or down until the pallet is approximately 1/16 inch [1.6 mm] higher than the wear plate (Figure 1.1, ref. A).

NOTE:

If necessary, install shims beneath the extension plates to obtain the 1/16 inch [1.6 mm] height difference. Save any remaining shims for future use to adjust for plate wear.

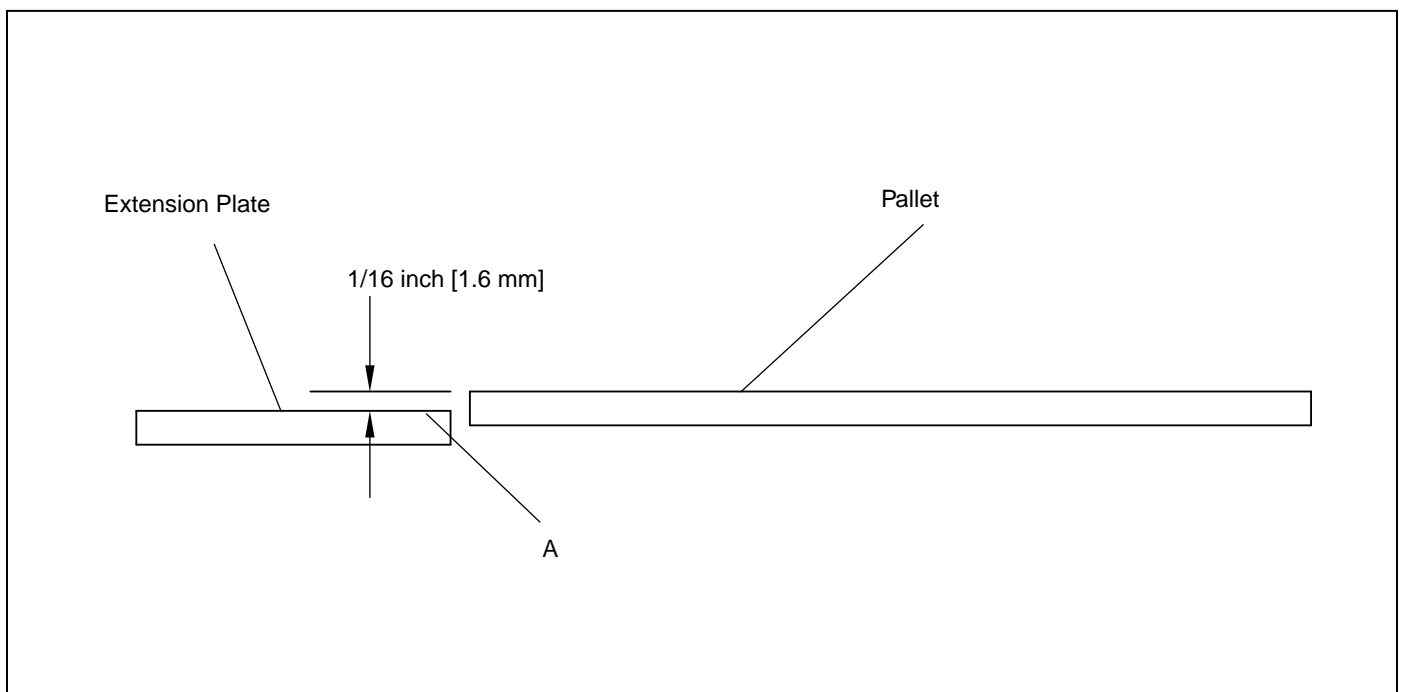

Figure 1.1 Installation

4. When the depalletter is in the proper orientation and at the proper height, loosen the three capscrews on each of the six legs to allow the extensions to slide down to the floor. Tighten all bolts on the legs to lock the extensions in place. For additional security, perform either of the following (see Figure 1.2):
 - Tack weld the leg extensions to the leg.
 - Position key stock so that it rests against the bottom of the leg and the side of the leg extension. Weld the key stock in place.
5. At all six legs, mark the floor at the hole in the base of the leg extension.

NOTE:

If necessary, move the depalletter out of the way to perform Step 6. Return it to perform Step 7.

6. Install the desired attaching hardware, using the floor marks (Step 5) as a guide.
7. Secure and level the depalletter.
8. After the depalletter has been properly leveled and secured, carefully remove it from the forklift or lifting device.

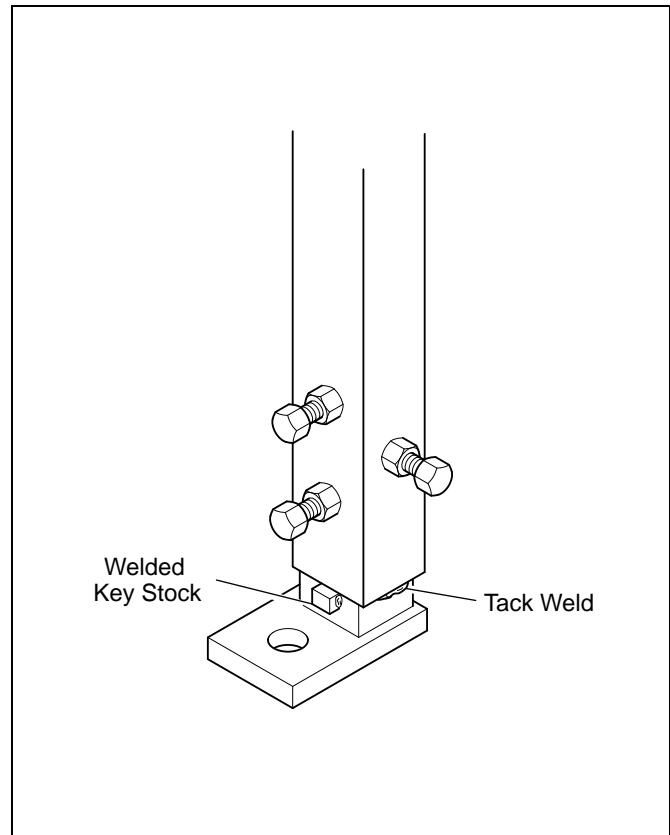

Figure 1.2 Leg Extension Adjustment

1.3 PALLET SUPPORT ADJUSTMENT

The pallet support adjustment prevents the pallet from tipping to one side as it is unloaded.

This adjustment is performed as follows:

1. Place an empty pallet on the conveyor at the unload position.
2. Loosen the two capscrews at each end of the support angle. (See Figure 1-3)
3. Adjust the support angle upward until both cam followers just touch the bottom of the pallet.
4. Hold the support angle in place and tighten both capscrews.

1.4 HYDRAULIC CONNECTIONS

The hydraulic manifold requires two hose assembly connections:

- Supply from the hydraulic power unit
- Fluid return to the tank

Both hose assemblies have a 3/4-12 female thread for connection to the hydraulic power supply. Route the hoses in such a way that they are not crimped, bent or touching any moving parts. If additional hose is needed, be sure to use only hose rated for a minimum of 2,000 psi [138 bar] operating pressure. (Recommended fluid power supply pressures are 800 to 1000 psi [55 to 69 bar].)



WARNING:
Use only hose rated for a minimum of 2,000 psi [138 bar] operating pressure. Improperly rated hose could break, causing fluid leakage and unsafe conditions.

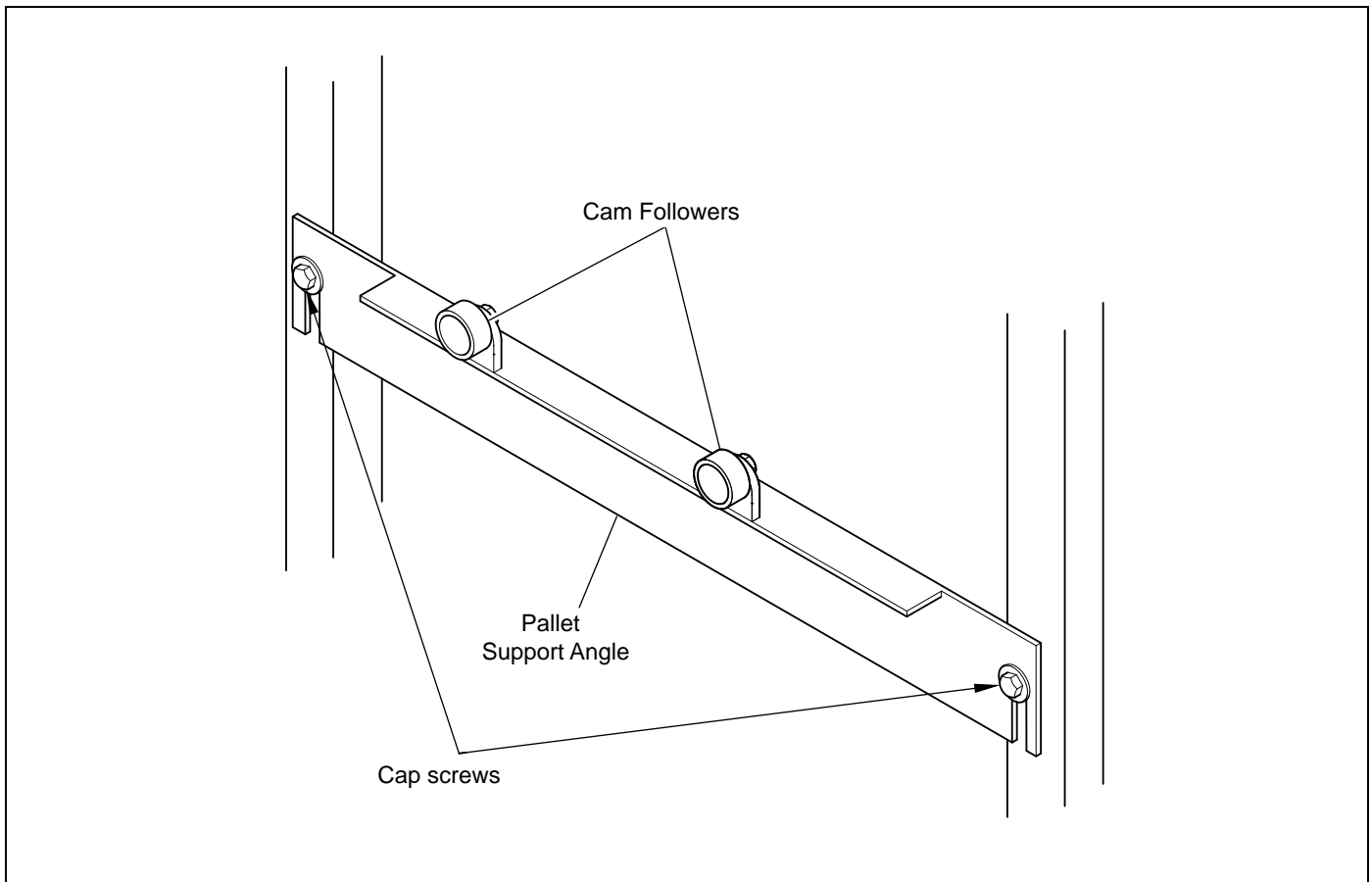

Figure 1.3 Pallet Support Angle

1.5 ELECTRICAL CONNECTIONS

Typical electrical connections include:

- Input and output connections to the system controller.
- 120 volt power connection.
- A proximity sensor to detect a “pallet hi-limit” condition. Mount the proximity sensor in an appropriate location on the Concrete Product Machine.
- Three-phase power connections for the unloading, pallet transfer, and pallet return conveyors.

The depalleter is shipped with all its dedicated components properly wired. There are usually other connections that need to be completed before the system is operational. The electrical schematics supplied with each depalleter list the components and their respective wire numbers. Refer to these prints when performing any electrical connections.



WARNING:

Electrical connections from the depalleter to other conveyor components may be required. Ensure all electrical circuits are shut down and locked out before performing any electrical work.